

**Quasar**

AUTOPAX™ System

Phone • Answering • faX system

MODEL NO. **PAX400H**

# OPERATING INSTRUCTIONS



Please read before use.

FOR ASSISTANCE, CALL  
1-800-CALL-FAX

# ● Important information

If required by the telephone company, inform them of the following.

- FCC Registration No.: (found on the rear side of the unit)
- Ringer Equivalence: 0.2B
- The particular telephone line to which the equipment is connected.

The unit must not be connected to a coin operated line. If you are on a party line, check with your local telephone company.

## **Ringer Equivalence Number (REN):**

This REN is useful in determining the quantity of devices you may connect to your telephone line and still have all of those devices ring when your telephone number is called. In most but not all areas the sum of the REN's of all devices connected to one line should not exceed five (5.0). To be certain of the number of devices you may connect to your line, as determined by the REN, you should contact your local telephone company to determine the maximum REN for your calling area.

In the event that terminal equipment causes harm to the telephone network, the telephone company should notify the customer, if possible, that service may be stopped. However, where prior notice is impractical, the company may temporarily cease service providing that they:

- a) Promptly notify the customer.
- b) Give the customer an opportunity to correct the problem with their equipment.
- c) Inform the customer of the right to bring a complaint to the Federal Communication Commission pursuant to procedures set out in F.C.C. Rules and Regulations Subpart E of Part 68.

The Telephone Company may make changes in its communications facilities, equipment operations or procedures, where such action is reasonably required in the operation of its business and is not inconsistent with the rules and regulations in F.C.C. Part 68. If such changes can be reasonably expected to render any customer terminal equipment incompatible with telephone company communications facilities, or require modification or alteration of such terminal equipment, or otherwise

materially affect its use or performance, the customer shall be given adequate notice in writing, to allow the customer an opportunity to maintain uninterrupted service.

When programming emergency numbers and/or making test calls to emergency numbers:

1. Remain on the line and briefly explain to the dispatcher the reason for the call before hanging up.
2. Perform such activities in the off-peak hours; such as early morning or late evenings.

This telephone provides magnetic coupling to hearing aids.

## **WARNING:**

**TO PREVENT FIRE OR SHOCK HAZARD, DO NOT EXPOSE THIS PRODUCT TO RAIN OR ANY TYPE OF MOISTURE.**

This equipment generates, uses, and can radiate radio frequency energy and if not installed and used in accordance with the instruction manual, may cause interference to radio communications. It has been tested and found to comply with the limits for a Class A computing device pursuant to Subpart J of Part 15 of FCC Rules, which are designed to provide reasonable protection against such interference when operated in a commercial environment. Operation of this equipment in a residential area is likely to cause interference in which case the user at his own expense will be required to take whatever measures may be required to correct the interference.

# ●Precaution

Keep the unit away from heating appliances such as radiators or air conditioning units.

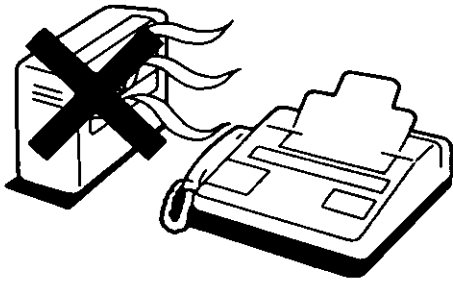

The unit and the cassette tape should not be exposed to direct sunlight.

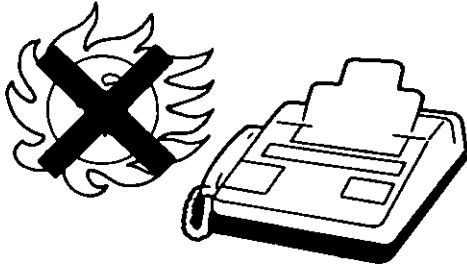

Do not use benzine, thinner, or the like, or any abrasive powder to clean the cabinet. Wipe it with a soft cloth.

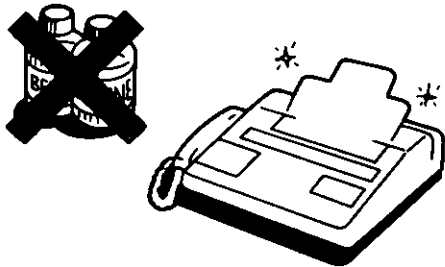

Keep the unit away from electrical noise generating devices such as fluorescent lamps and motors.

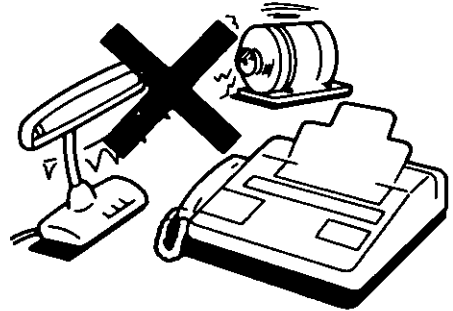

The unit and the cassette tape should be kept free from dust, moisture, high temperature and vibration.

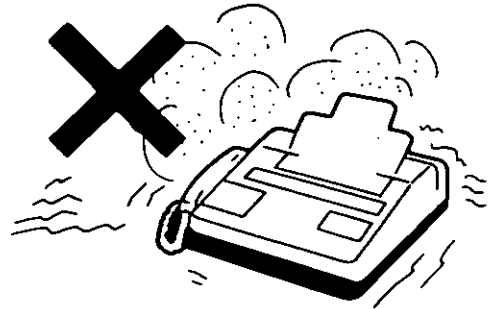

Do not place any covering over the unit while it is turned on.

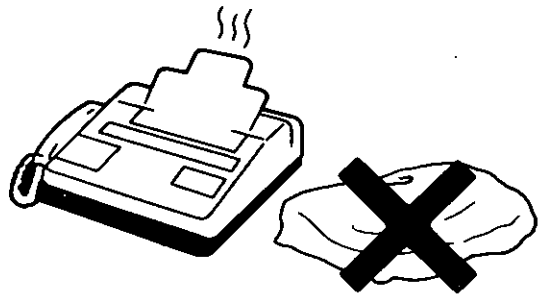

# •Introduction

Thank you for purchasing the Quasar Telephone Answering Device with Facsimile. Before using the unit, please read these OPERATING INSTRUCTIONS. The instructions have been written to take the user from initial set-up through the operation of advanced features.

This manual is divided into 7 chapters-Initial Preparation, Basic, Intermediate, Advanced Instruction, Printing Reports and Lists, System Programming Function, and Troubleshooting, Maintenance and Specifications. Each chapter has been divided into three sections: Telephone, Answering Device and Facsimile. Cross references are included to allow the user to continue the set-up and usage (from initial set-up through advanced instruction) one section at a time.

## Contents

### **CHAPTER 1 Unpacking and Initial Preparation**

#### **CHAPTER 2 Basic Features**

Setting date

Telephone: Making and answering voice calls

Answering Device: Recording an outgoing message (OGM)

Facsimile and Copy: Transmitting documents, Receiving documents and/or voice-message and Making copies

#### **CHAPTER 3 Intermediate Features**

Programming functions: Setting your logo and telephone number

Programming phone numbers for automatic dialing

Telephone: Making voice calls using the automatic dialing

Answering Device: Operating as an answering device

Facsimile: Automatic transmission and Voice contact

#### **CHAPTER 4 Advanced Features**

Telephone: Combination dialing, TONE, FLASH and PAUSE button usage

Answering Device: Operating the answering device from a remote phone and Privacy ring

Facsimile: Auto receive timer, Polling and Network communication

### **CHAPTER 5 Printing Reports and Lists**

### **CHAPTER 6 System Programming Functions**

### **CHAPTER 7 Troubleshooting and Maintenance**

# CHAPTER 1

## *Unpacking and Initial Preparation*

<b>Accessories</b> .....	1-2
<b>Location of controls</b> .....	1-3
<b>Installation connections</b> .....	1-5
<b>Recording paper installation</b> .....	1-6
<b>Document feeder tray and receiving tray installation</b> .....	1-8
<b>Micro cassette tape installation</b> .....	1-10
<b>Selector settings</b> .....	1-11
<b>Turning the POWER switch on</b> .....	1-11
<b>The buttons and indicators</b> .....	1-12
<b>Setting the RECEIVE MODE</b> .....	1-14

# ●Accessories

1. Carefully remove the unit from the packing carton.
2. Examine the unit for signs of shipping damage.
3. All of the necessary accessories, hardware, cords, etc., are packed with the unit. Make sure that you have removed all accessories before discarding the packing material.
4. Check that all of the accessories are included. If you are missing any item, consult your place of purchase.

Telephone line cord ..... one

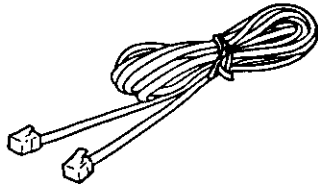

Handset ..... one

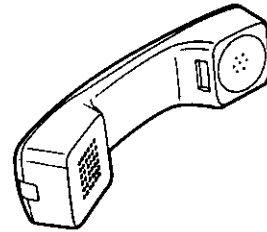

Micro cassette tape ..... one

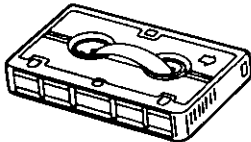

Handset cord ..... one

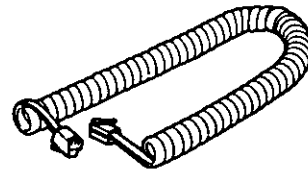

Document feeder tray ..... one

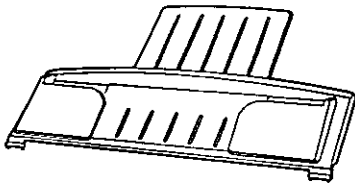

Recording paper ..... one  
216 mm x 15 m (8½" x 49') roll

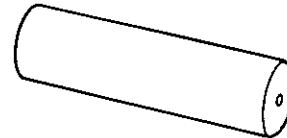

Receiving tray ..... one

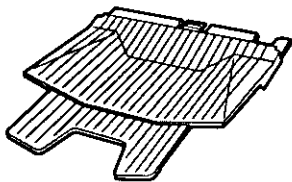

AC power cord ..... one

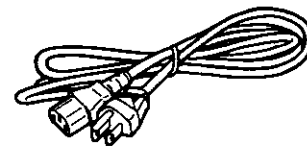

Diverter ..... one

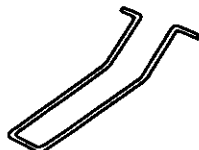

Printed materials:  
Operating Instructions  
Quick reference card for facsimile  
(English/Spanish)  
Quick reference card for tone remote control  
Fax correspondence sheet  
Speed dialer list

# •Location of controls

Front view

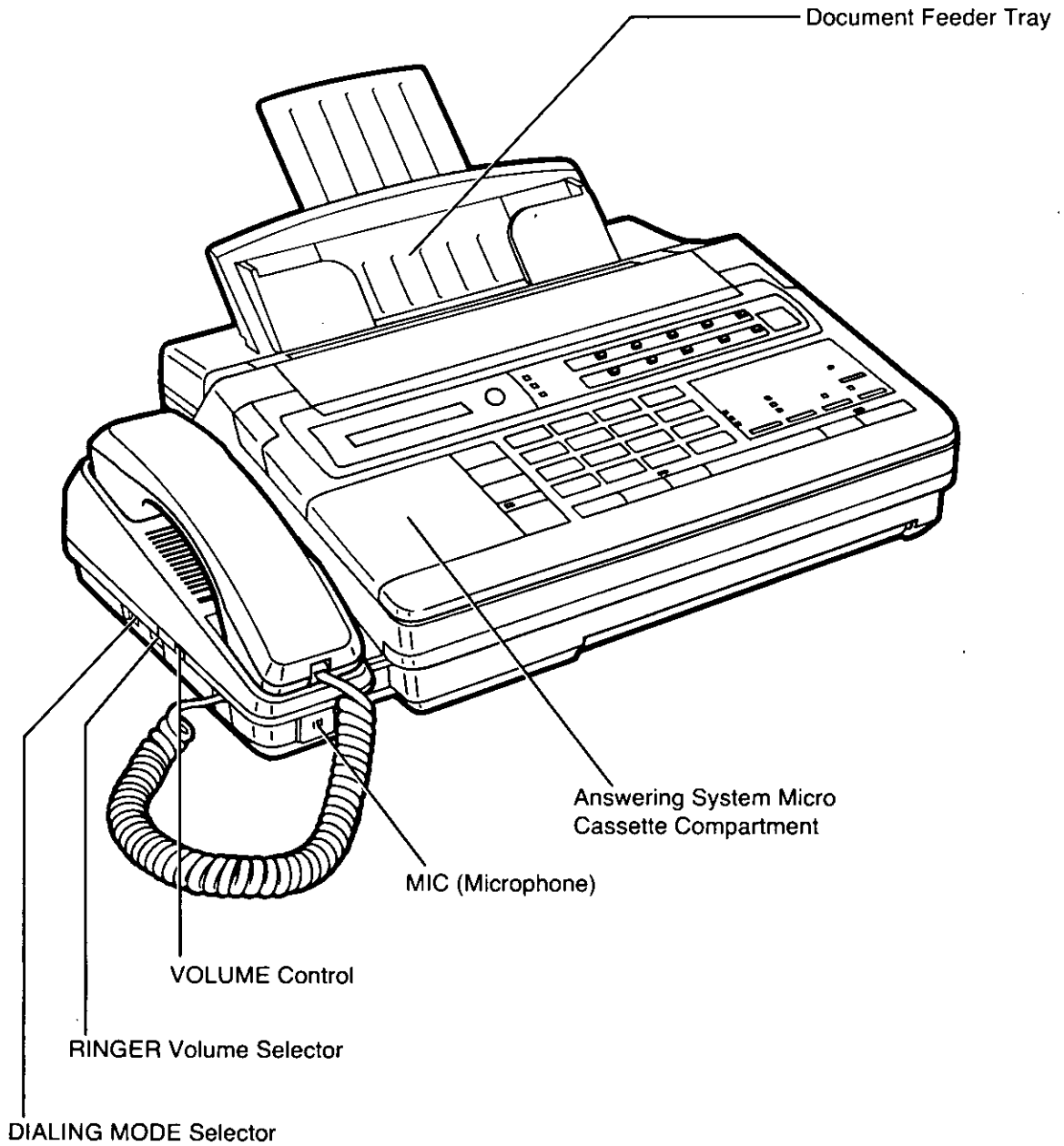

# Rear view

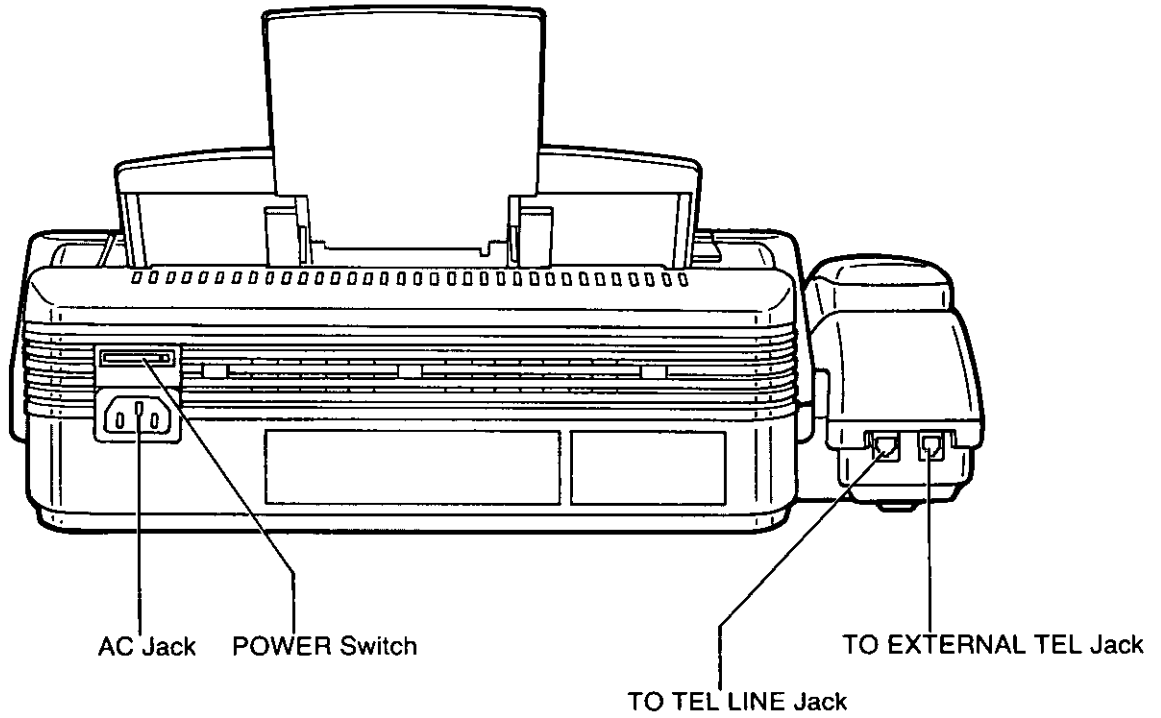

# Side view

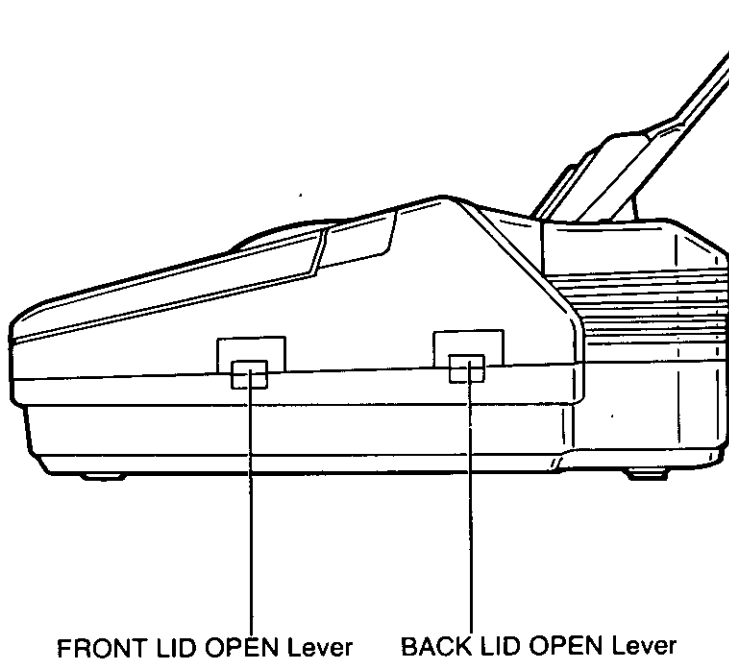



# ●Installation connections

## CONNECT TO THE UNIT:

1. The AC power cord
2. Telephone line cord
3. Handset cord

## CONNECT TO OUTLET:

1. AC outlet
2. Telephone line

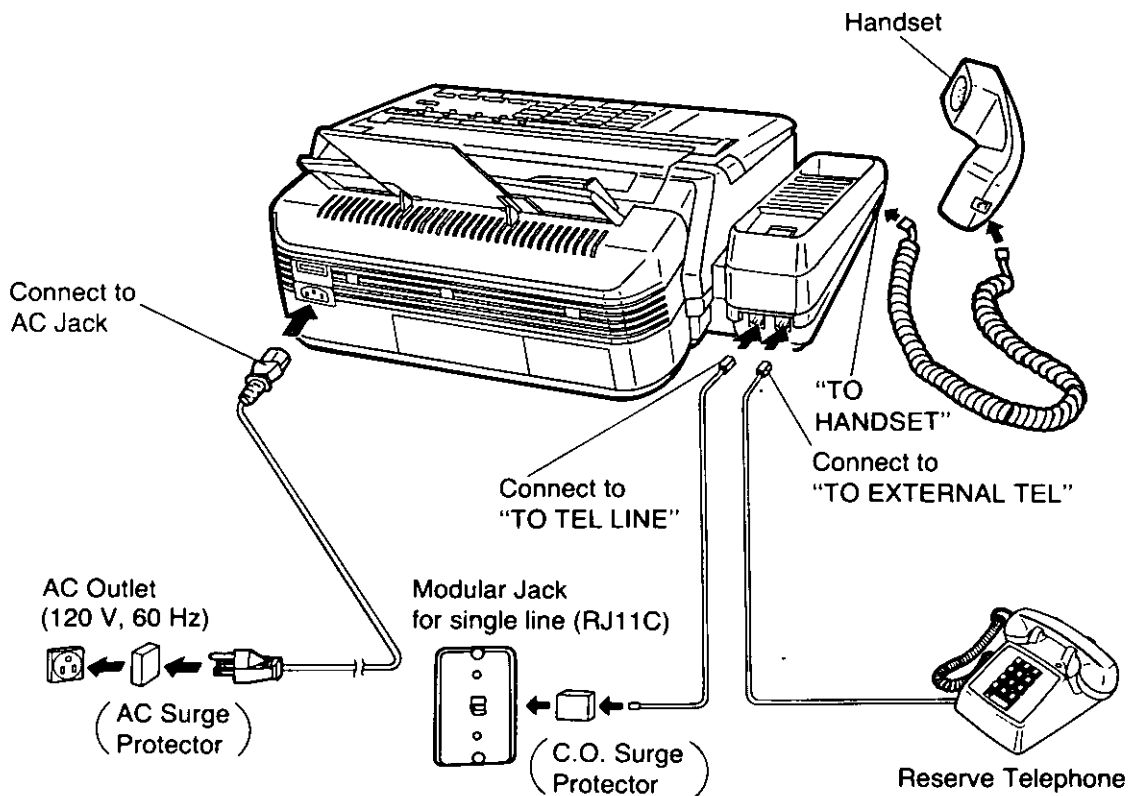

## HELPFUL HINTS

- This unit is equipped with a 3-wire grounded plug for safety. If you are unable to insert the plug into your outlet, contact your electrician to replace your outlet.
- We recommend you use an exclusive AC outlet to avoid interference from other equipment.
- For additional equipment protection we recommend the use of a surge protector.
- The unit will not function during a power failure or when the power is turned off. However, if you connect a reserve telephone to the port marked "TO EXTERNAL TEL" (above), you will be able to make calls.
- If your unit is connected to the same line as other extensions, do not use other extension during fax transmission and reception. Image quality will be affected.

# ●Recording paper installation

Follow the steps below to install a new roll of recording paper.

- 1 Press the FRONT LID OPEN lever down to open the cover.

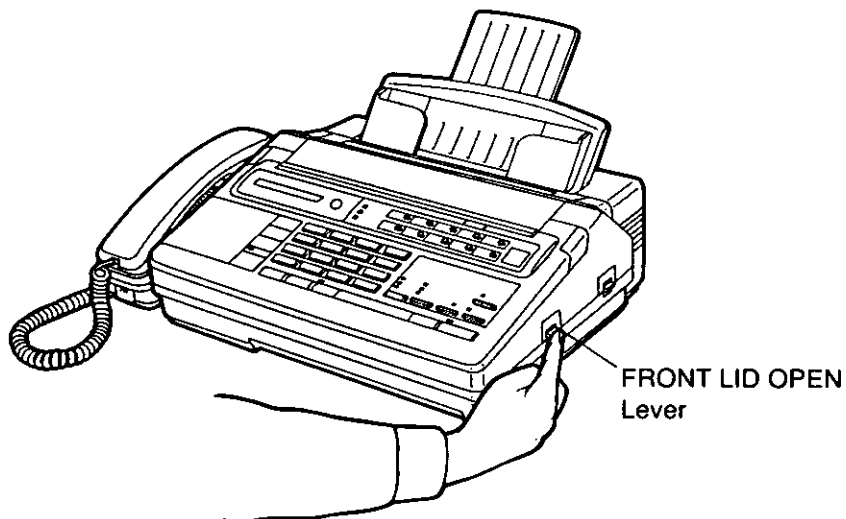

- 2 Place a recording paper roll into the paper compartment. Make sure that the shiny side of the paper is facing up and that there is no slack in the paper roll.

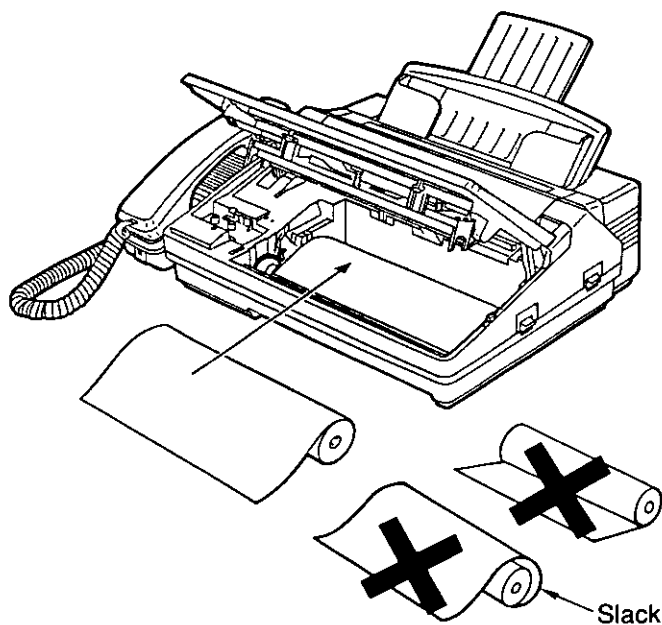

# 3

Insert the recording paper between the upper and the lower guide plates and pull the paper a few centimeters (one or two inches) out of the unit.

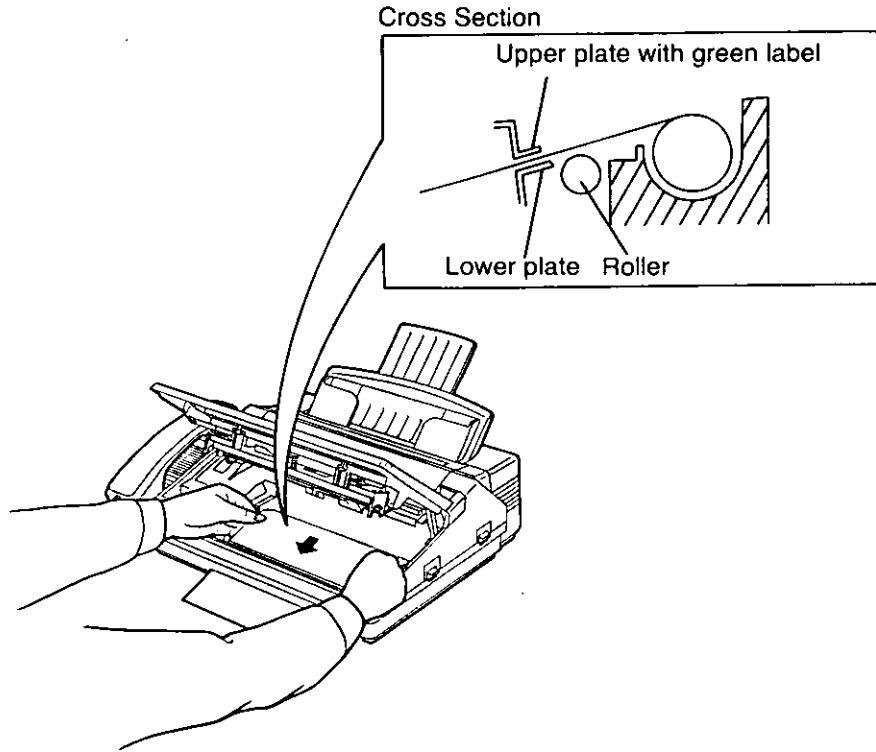

# 4

Close the cover carefully by pressing down on both ends gently.

If the unit is on, the recording paper will project slightly and be cut automatically.

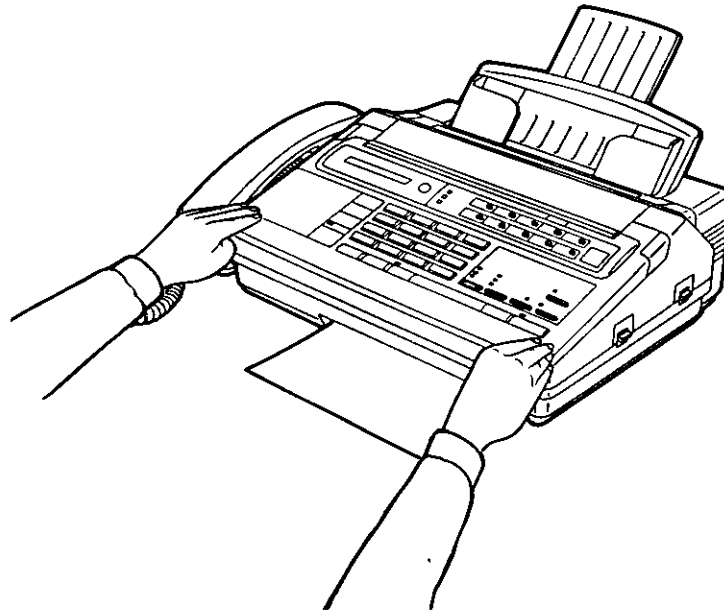

#### HELPFUL HINT

- For replacement use only thermal facsimile paper, shiny side out.
- Use of incorrect paper may affect print quality or cause excessive thermal head wear.

# ● Document feeder tray and receiving tray installation

1

Insert the two tabs "A" of the tray into the two grooves on the unit.

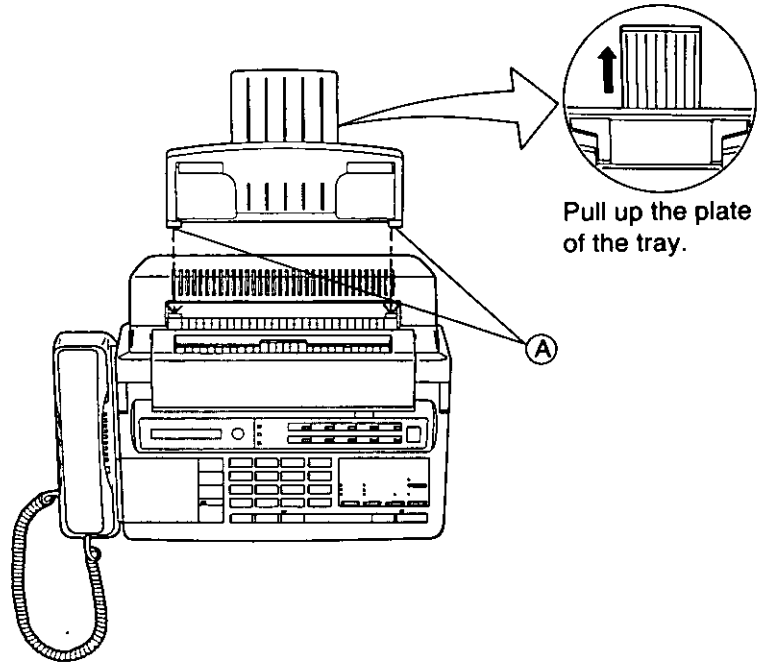

2

Press the tray "B" back with both hands until the two fins "C" on the rear of the tray click into place.

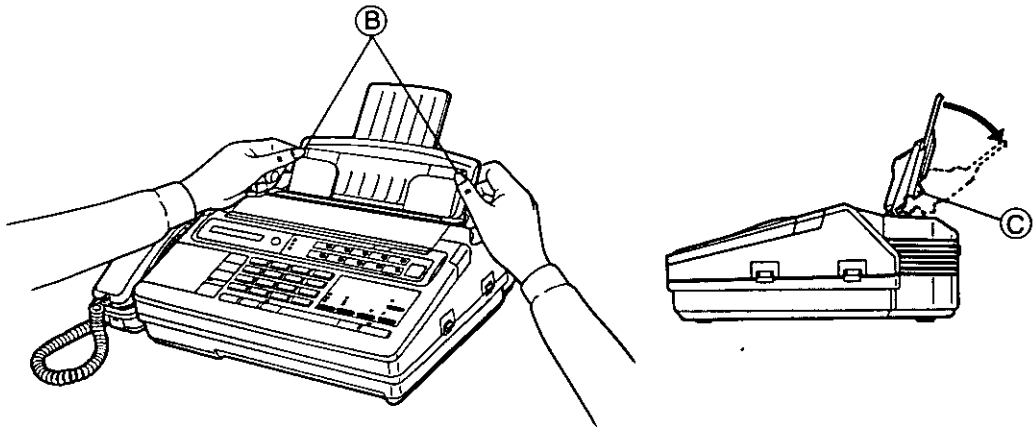

# 3

Insert the receiving tray.  
Pull the document plate "D" forward after inserting the receiving tray.

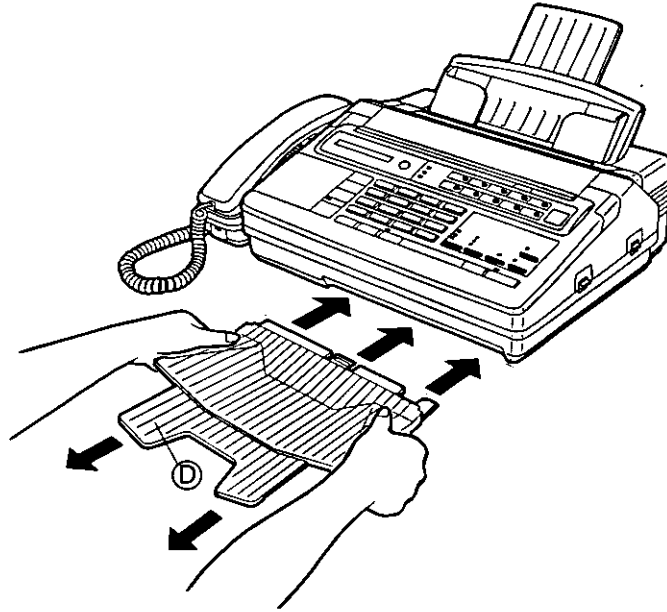

# 4

Fit the diverter as shown below.

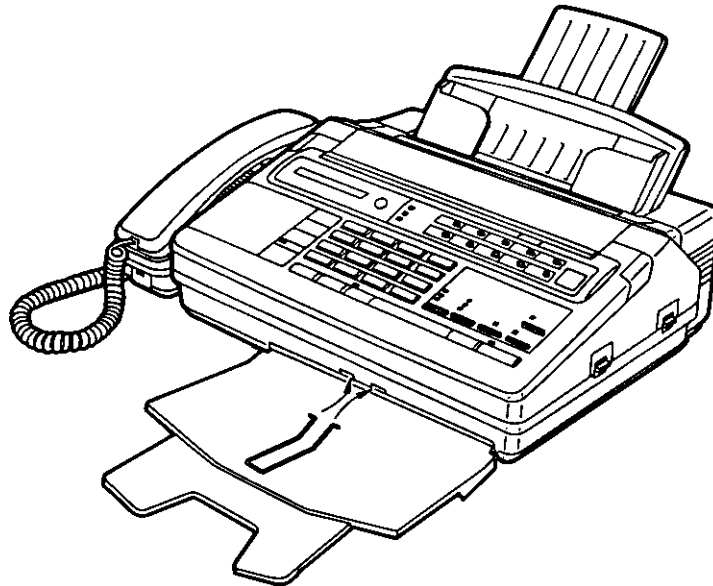

# ●Micro cassette tape installation

1. Remove slack from tape, (if any) using a pencil and rotating the tape reel, as shown.

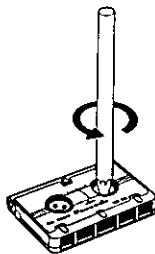

2. Open the compartment cover.
3. Insert the cassette tape into the compartment by
  - (A) Slide in
  - (B) Push down
4. Close the compartment cover.

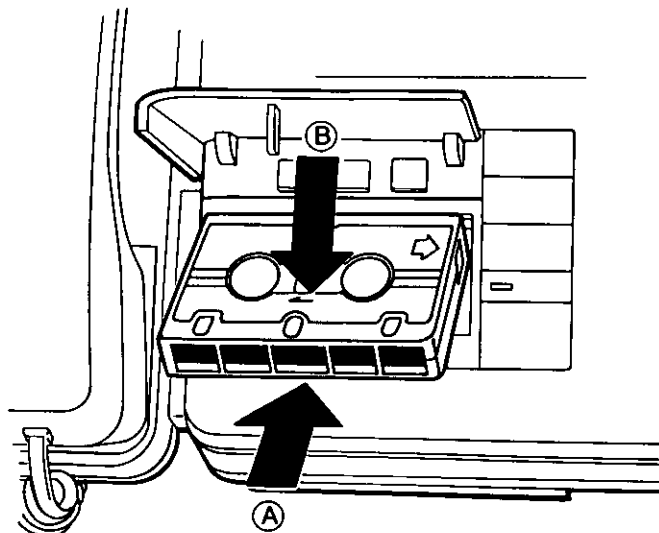

## HELPFUL HINTS

- For optimum sound quality, use side 2 of the cassette tape after 6 months and replace the tape after 1 year.
- Never place a cassette tape near a magnetic source such as a magnet or a TV set because it may erase or interfere with any messages on the tape.
- Replace the tape if it breaks or becomes worn.

## •Selector settings

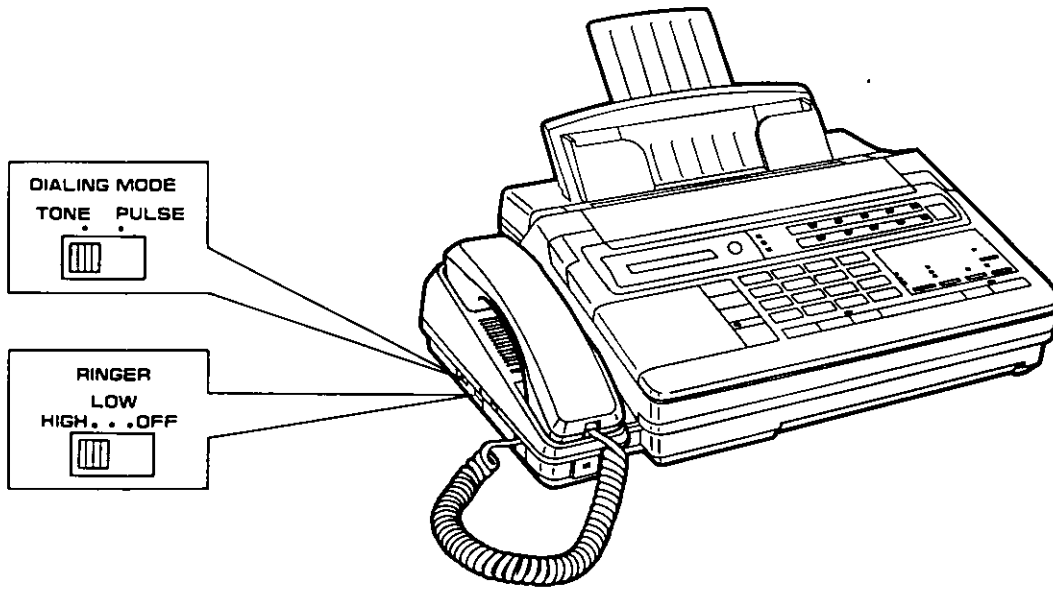

### **DIALING MODE selector:**

If your line has:

1. Touch tone service, set the selector to "TONE".
2. Rotary pulse dial service, set the selector to "PULSE".

### **RINGER volume selector:**

**HIGH:** The ringing sound will be loud.

**LOW:** The ringing sound will be soft.

**OFF:** The unit will not ring.

## •Turning the POWER switch on

Before turning the POWER switch on, confirm the following:

1. The cassette tape and the recording paper are installed properly.
2. The handset is on the cradle.

Turn the POWER switch to the "ON (I)" position.

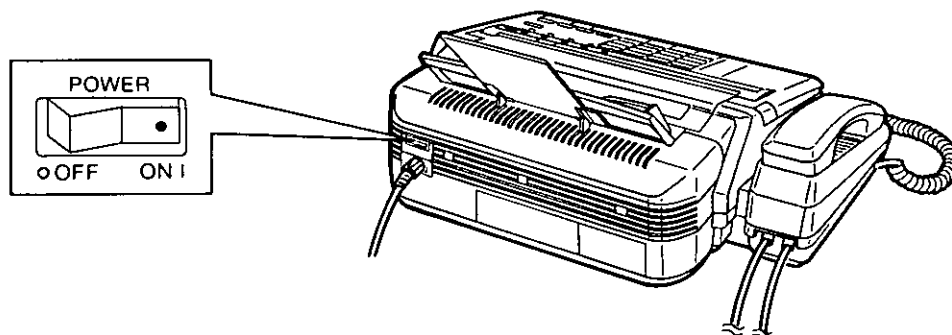

### **HELPFUL HINT**

- When you use the unit for the first time, the display shows "E-30". Record your OGM. See page 2-6.

# •The buttons and indicators

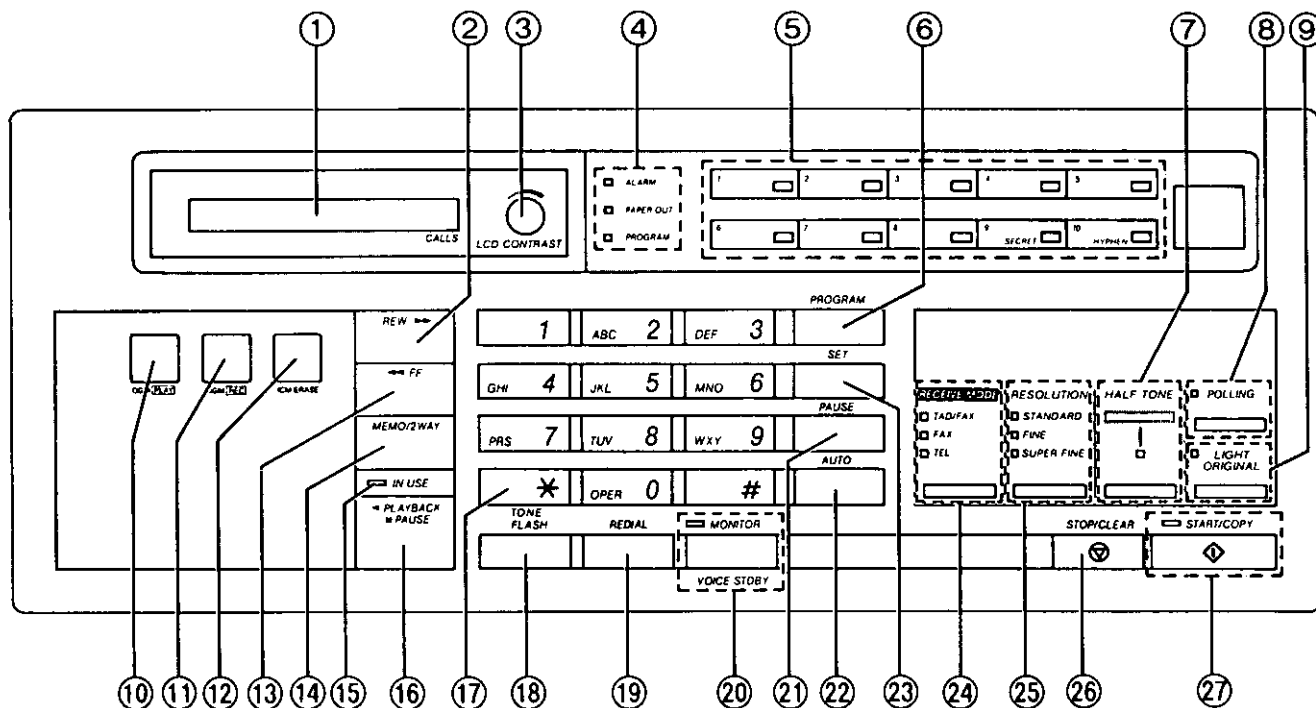

① **LCD (Liquid Crystal Display)**

② **REW (REWIND) Button:**

Used to run the tape quickly backward to a desired point.

③ **LCD CONTRAST:**

Rotate to adjust to the best display intensity.

④ **ALARM Indicator:**

The indicator lights when any trouble occurs.

**PAPER OUT Indicator:**

The indicator lights when the recording paper roll is empty.

**PROGRAM Indicator:**

The indicator lights or flashes when you are programming the unit.

⑤ **Direct Call Station Keys:**

Used for one touch dialing

⑥ **PROGRAM Button:**

Used to start or end programming functions.

⑦ **HALF TONE Button and Indicator:**

Press to send a document containing photographs, shaded drawings and the like. The indicator lights when this feature is on.

⑧ **POLLING Button and Indicator:**

Used for polling function. The indicator lights or flashes when this feature is on.



- ⑨ **LIGHT ORIGINAL Button and Indicator:**  
Used to transmit or copy originals with faint writing. The indicator lights when this feature is on.
- ⑩ **OGM PLAY Button:**  
Used to replay your outgoing message.
- ⑪ **OGM REC Button:**  
Used to record your outgoing message.
- ⑫ **ICM ERASE Button:**  
Used to erase recorded incoming messages at high speed.
- ⑬ **FF (FAST FORWARD) Button:**  
Used to run the tape quickly forward to a desired point.
- ⑭ **MEMO/2 WAY Button:**  
Used to start and stop recording of a memo message or a telephone conversation.
- ⑮ **IN USE Indicator:**  
The indicator lights or flashes when the answering device is in use.
- ⑯ **PLAYBACK/PAUSE Button:**  
Used to play back recorded messages, or interrupt playback or FF/REW operation.
- ⑰ **tone Button:**  
Used to change the dialing mode from pulse to tone during a dialing operation.
- ⑱ **FLASH Button:**  
Used to access some features of your host PBX.
- ⑲ **REDIAL Button:**  
Used to redial the last dialed number.
- ⑳ **MONITOR (VOICE STDBY) Button and Indicator:**  
Used for on-hook dialing and voice contact features. The indicator lights when these functions are on.
- ㉑ **PAUSE Button:**  
Used to insert a pause into a phone number during programming.
- ㉒ **AUTO Button:**  
Used for speed dialing.
- ㉓ **SET Button:**  
Used to store parameters during programming.
- ㉔ **RECEIVE MODE Button and Indicators:**  
Used to select the desired receiving mode.  
The indicators light to show the mode in which the unit is set.
- ㉕ **RESOLUTION Button and Indicators:**  
Used to adjust scanning line density. The indicators light to show which setting you are using.
- ㉖ **STOP/CLEAR Button:**  
Used to cancel transmission or copying operation. Also used during programming to clear the previously entered parameters.
- ㉗ **START/COPY Button and Indicator:**  
Used to start transmission and copy functions. The indicator lights when these functions are on.

# ●Setting the RECEIVE MODE

Press the RECEIVE MODE button to set to:

- A) TAD/FAX —When you want to use TAD and facsimile.
- B) FAX —When you want to use facsimile only.
- C) TEL —When you want to use as a standard telephone only.

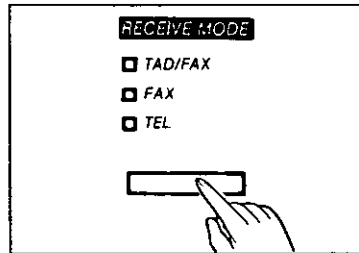

Press the RECEIVE MODE button to set to TAD/FAX, FAX or TEL.

## HELPFUL HINTS

### **TAD/FAX mode:**

- The unit will automatically distinguish between voice and fax calls. If a fax tone is heard, the unit will switch automatically to the fax mode. If the caller's voice is heard within 5 seconds of the end of the OGM (see page 2-6), the answering device will receive message.

You are also able to speak with the other party and transmit or receive documents.

### **FAX mode:**

- When the unit is in this mode you will only be able to receive fax calls. You are still able to make outgoing voice-calls.

### **TEL mode:**

- For use as a standard telephone, you can also receive a fax during telephone conversation by pressing the START/COPY button.

# CHAPTER 2

## Basic Features

Setting the system clock (SET DATE) .....	2-2
---	-----

### Telephone

<b>Making and answering voice calls</b> .....	2-4
Making voice calls .....	2-4
Answering voice calls .....	2-4
Redialing (Repeat call attempt) .....	2-5

### Answering device

<b>Recording an outgoing message (OGM)</b> .....	2-6
Suggested message .....	2-6
Recording your OGM .....	2-7
Verifying your OGM .....	2-7
Re-recording of OGM .....	2-7

### Facsimile and copy

<b>Before transmitting documents</b> .....	2-8
Acceptable documents .....	2-8
Resolution and contrast .....	2-9
<b>Manual transmission</b> .....	2-10
Transmitting documents during a conversation .....	2-10
Interrupting transmission .....	2-10
Adding extra pages .....	2-10
Transmitting documents .....	2-11
Transmitting documents using the REDIAL button .....	2-11
<b>Receiving documents and/or voice-messages</b> .....	2-12
Automatic reception .....	2-12
Manual reception .....	2-12
Manual reception during telephone conversation .....	2-13
<b>Making copies</b> .....	2-14

# ●Setting the system clock (SET DATE)

The internal clock of the unit will print the date and time on the top line of all fax messages you transmit.

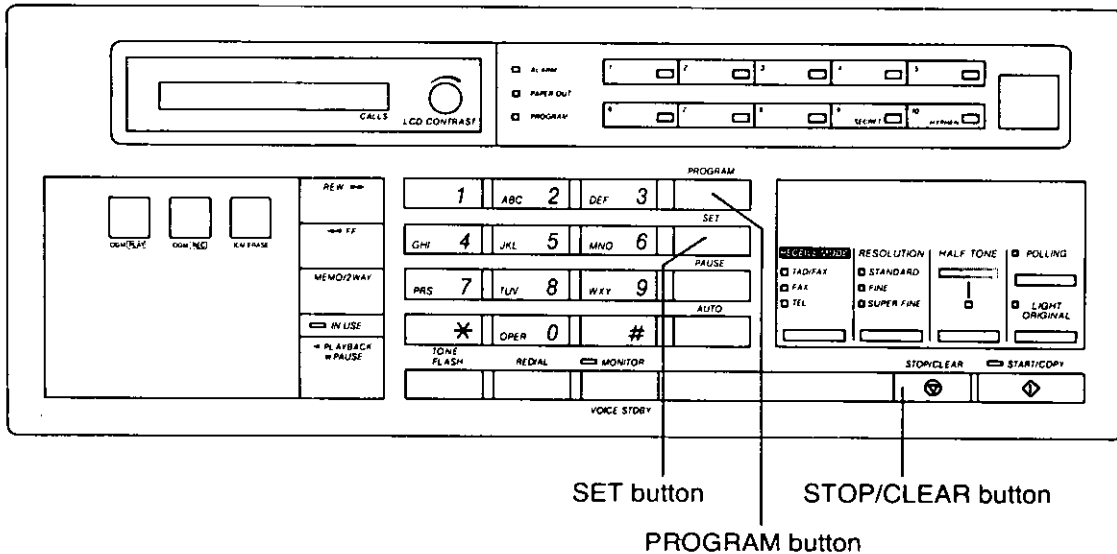

## HELPFUL HINT

●When the unit is in idle status, the display shows the current time and the number of recorded incoming messages. Entered "month/date/year" are not displayed. These settings appear on the top line of all the documents you transmit and the fax communication reports such as JOURNAL report and TX report.

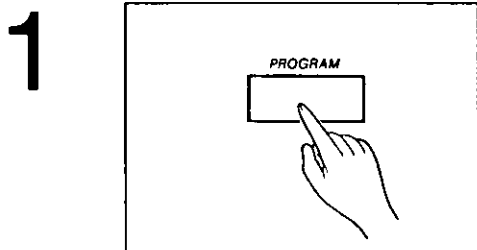

Press the PROGRAM button.

The PROGRAM indicator lights and the display shows "P-\_"

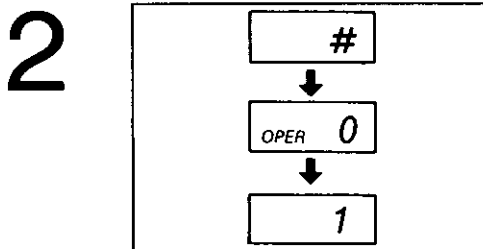

Press "#", then press "01" for SET DATE setting.

The display shows "P-F01".

# 3

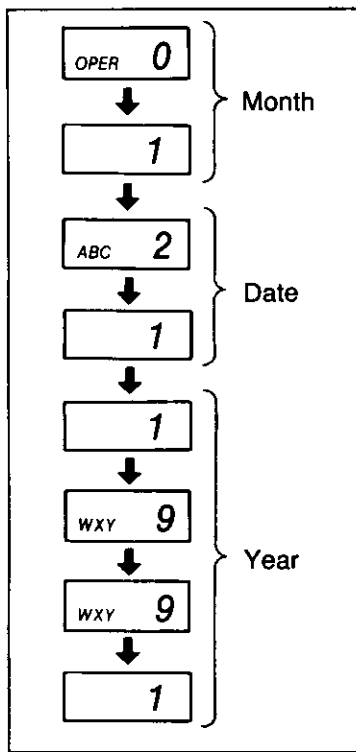

Enter current month/date/year using the numbers on the telephone keypad.  
(for example: Jan. 21 1991)

The display shows "P-F01 01-21 1991".

# 4

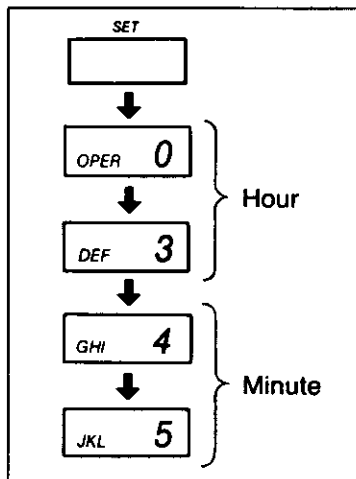

Press the SET button. The display will show the previously assigned time. Enter the current time (for example: 03:45 PM) using 4 digits.

The display shows "PM P-F01 03-45".  
"PM" or "AM" is shown alternately by each pressing of "\*".

# 5

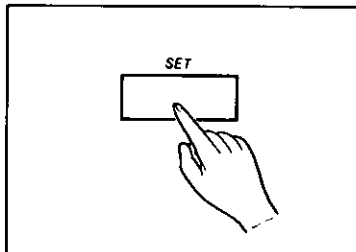

Press the SET button to store the programming in memory.

The display shows "P-\_".

# 6

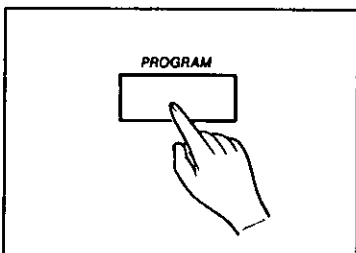

Press the PROGRAM button to end the operation.

The PROGRAM indicator goes out and the display shows the current time.

# ● Making and answering voice calls

## Making voice calls

### Using the handset:

1. Lift the handset.
2. Dial the phone number.

### Using on-hook dialing:

1

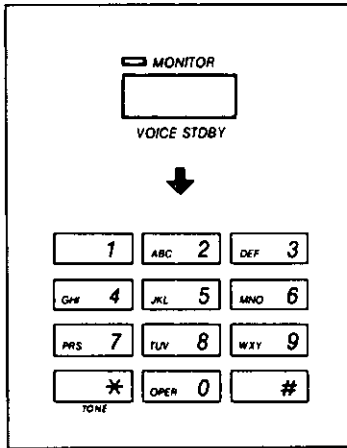

Press the MONITOR button, then dial the phone number.

The MONITOR indicator lights.

2

When the other party answers your call, lift the handset and talk with it.

## Answering voice calls

Set the RECEIVE MODE to TEL. (See page 1-14.)

When the phone rings, lift the handset to answer the call.

## Redialing (Repeat call attempt)

If the line is busy or you wish to redial the last dialed number, you can redial by simply pressing the REDIAL button.

1

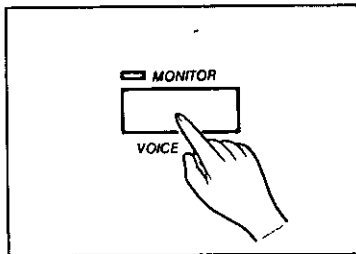

Press the MONITOR button or lift the handset.

2

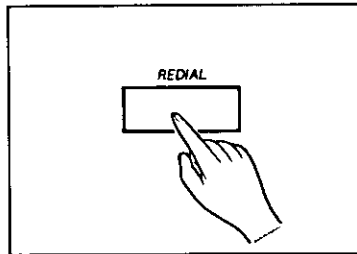

Press the REDIAL button.

### HELPFUL HINTS

- If the line is busy when using the MONITOR button, the unit redials the last dialed number automatically up to 15 times within 10 minutes.
- During interval between each redialing, the MONITOR indicator flashes.
- To cancel automatic redialing, press the FLASH button or the STOP/CLEAR button.

TO CONTINUE TELEPHONE SET UP ONLY, SEE PAGE 3-13.

## ●Recording an outgoing message (OGM)

### HELPFUL HINTS

- The outgoing message (OGM) tells the caller that you are out, and asks to leave a voice-message and to send a fax message. Before using your unit as both an answering device and a facsimile you should first record your outgoing message.
- You can store a personal OGM up to 16 seconds on the voice-recordable microchip. Once recorded, the OGM will be automatically recorded on the micro cassette tape as a backup in case of power failure.
- If a power failure takes place or the POWER switch is turned off, the OGM recorded on the microchip will be erased. However, after the power is restored, the unit will automatically re-record the OGM onto the microchip using the OGM recorded on the tape. You need not re-record your OGM.

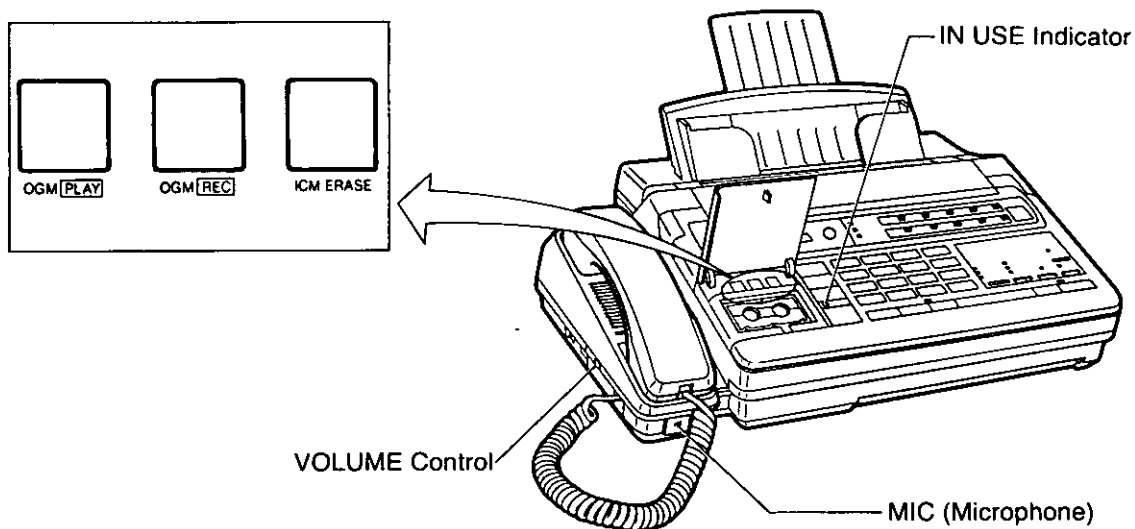

## Suggested message

Record your OGM referring to the examples below.

*"This is (your name, business and/or telephone number). We are out right now. To send a fax, start transmission. To leave a message, speak after the long beep. Thank you."*

*"This is (your name, business and/or telephone number). We are out right now. To send a fax, start transmission. To leave a message, speak for up to 1 minute after the long beep. Thank you."*

You can choose from two types of recording time of incoming messages. When the unit is in the "VOX" position, the recording time is unlimited, and when in the "1 MIN" position, the recording time is limited to 1 minute. The two examples above correspond to these two conditions.

The unit is preprogrammed to the "VOX" position. To change the recording time, see page 6-4.



# Recording your OGM

## HELPFUL HINTS

- The recording time is limited to 16 seconds. For optimum performance, we recommend that you record your OGM within 12 seconds.
- Do not pause for over 2 seconds while recording your OGM. If 16 seconds pass or a pause continues for more than 2 seconds, the unit will finish recording. The rest of your message will not be recorded.

1

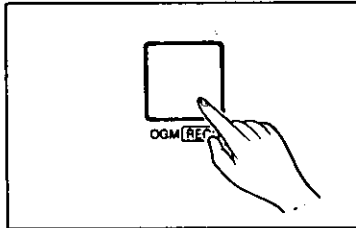

Press the OGM REC button until a long beep is heard, then release it.

The IN USE indicator lights.  
The display counts the seconds that you use for your OGM recording.

2

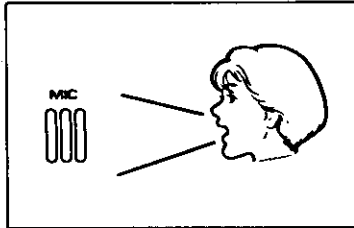

After the beep, speak immediately, clearly and loudly, toward the microphone from a distance of approximately 20 cm (8 inches).

3

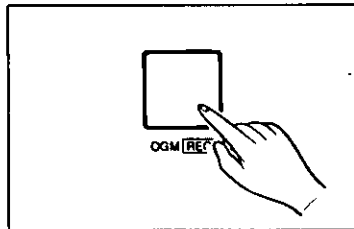

After recording, press the OGM REC button again.

## HELPFUL HINTS

- The unit plays back your OGM so that you can confirm your message. Adjust the VOLUME control to a suitable level.
- If you want to change your OGM, perform from step 1 again. The previous message will be automatically erased and the new message will be recorded.

## Verifying your OGM

Press the OGM PLAY button.

The unit replays your outgoing message.

## Re-recording of OGM

When you replace the cassette tape with a new one or you use the opposite side (side-2), you have to record an OGM again.

TO CONTINUE ANSWERING DEVICE SET UP ONLY, SEE PAGE 3-14.

## ●Before transmitting documents

### Acceptable documents

The unit can transmit documents that meet the following conditions.

- Paper width should be 128 mm (5") to 216 mm (8½").
- Maximum paper length should not exceed 600 mm (23⅝").
- Effective scanning width should be up to 208 mm (8¾").
- Paper weight should be 45 g/m<sup>2</sup> (12 pounds) to 90 g/m<sup>2</sup> (24 pounds).

#### Automatic document feeder:

- Up to 10 sheets of paper can be set in the document tray at a time.
- Paper weight should be 60 g/m<sup>2</sup> (16 pounds) to 75 g/m<sup>2</sup> (20 pounds).
- Paper with a coated surface must not be used.

#### Maximum paper size

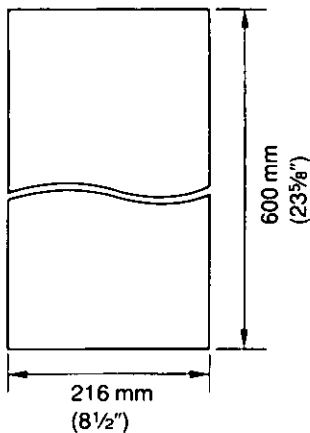

#### Effective scanning width

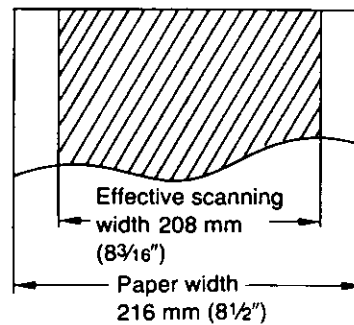

Do not use the following types of documents or it may jam. Make a copy of such documents and feed a copy into the unit.

- Paper with chemically treated surface such as carbon paper or carbonless duplicating paper
- Heavily curled, creased or torn paper
- Paper with a coated surface
- Small size paper such as a slip or voucher
- Thin paper less than 45 g/m<sup>2</sup> (12 pounds)
- Thick paper over 90 g/m<sup>2</sup> (24 pounds)
- Paper with faint contrast between the print and the background
- Paper with printing on the reverse side that can be seen through from the front (e.g. newspaper)

Remove clips, staples or other similar objects from a document before feeding it into the unit. Make sure that any ink or paste on the document is completely dry before feeding it into the unit.

#### HELPFUL HINT

- A document whose length exceeds 600 mm (23⅝") cannot be transmitted. When you feed such documents, the unit stops transmitting and a long beep will be heard. If this happens, press the STOP/CLEAR button and remove the document.
- If a document is electrostatically charged, the automatic document feeder may not function properly.

# Resolution and contrast

You can set the following functions depending on the quality of an original. Set the functions before transmitting or copying. If you set them during transmission, they will be effective from the next sheet transmitted.

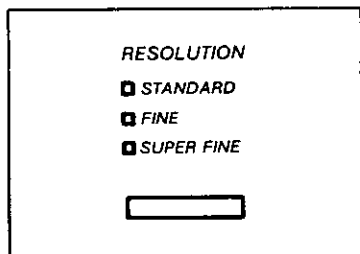

## **RESOLUTION:**

STANDARD is suitable for printed or typewritten originals with normal size characters.

FINE is suitable for originals written with small characters.

SUPER FINE doubles the resolution of FINE.

(SUPER FINE only works between Quasar compatible machines such as PAX400H, PAX600H.)

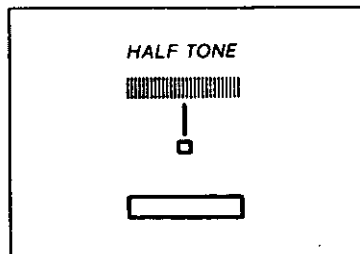

## **HALF TONE:**

HALF TONE is useful when sending originals containing photographs, shaded drawings, etc.

When you use this feature, resolution (FINE) is selected automatically.

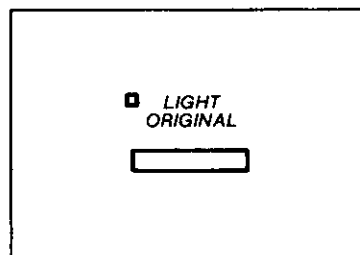

## **LIGHT ORIGINAL:**

LIGHT ORIGINAL is useful when transmitting or copying originals with faint writing.

# •Manual transmission

## Transmitting documents during a conversation

You can transmit documents during a telephone conversation.

1



Insert the documents **FACE DOWN** during a telephone conversation, then require the other party to perform fax reception.

The unit can accept up to 10 sheets of paper at a time.

2

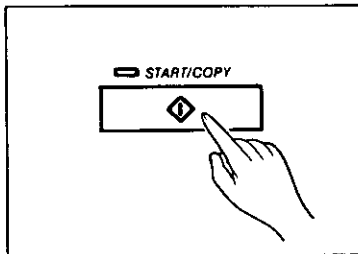

Press the **START/COPY** button when a fax tone is heard, then place the handset on the cradle.

The unit feeds and transmits the documents. The display shows the number of each page ("P-01" through "P-99") during a fax transmission.

If you do not replace the handset, the unit will automatically call the other party after the transmission. For further details, see "Voice contact" on page 3-20.

## Interrupting transmission

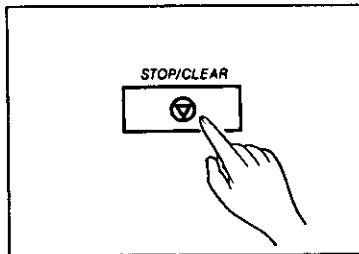

Press the **STOP/CLEAR** button until a beep sounds.

The transmission is interrupted. To eject the document, press the **STOP/CLEAR** button again.

## Adding extra pages

If you want to send 11 or more sheets at a time, insert the documents up to 10 sheets of paper first, and add the extra pages up to 10 sheets before the last page feeds into the unit.

## Transmitting documents

1

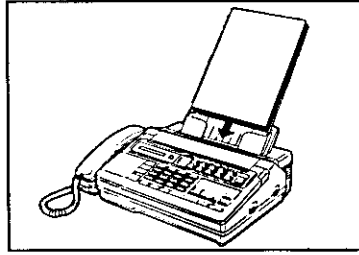

Insert the documents FACE DOWN.

2

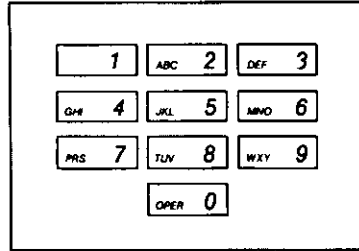

Dial the phone number by using the dial keypad.

3

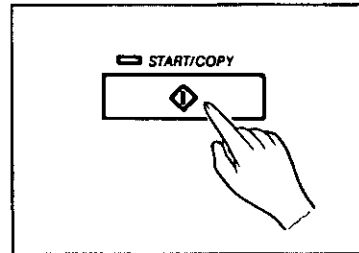

Press the START/COPY button.

The unit dials and transmits the documents automatically.

### **Automatic redialing:**

If there is no answer or the line is busy, the unit will automatically redial the number up to 6 times within 10 minutes. To cancel automatic redialing, press the FLASH button or the STOP/CLEAR button.

## Transmitting documents using the REDIAL button

You can transmit documents to the last dialed number using the REDIAL button.

1

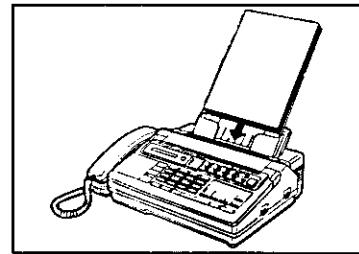

Insert the documents FACE DOWN.

2

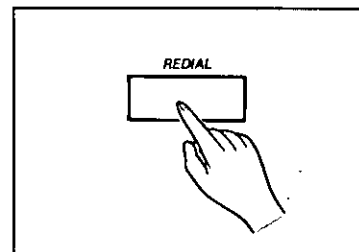

Press the REDIAL button.

The unit dials the last dialed number and transmits the documents automatically.

### **Automatic redialing:**

If there is no answer or the line is busy, the unit will automatically redial the number up to 6 times within 10 minutes. To cancel automatic redialing, press the FLASH button or the STOP/CLEAR button.

# ●Receiving documents and/or voice-messages

## Automatic reception

Set the RECEIVE MODE to either:

A) TAD/FAX mode

B) FAX mode

See page 1-14.

### HELPFUL HINT

- The unit will answer on the first ring by default. You can change the ring count according to the instructions found on page 6-5. If you find difficulty in receiving facsimile from machines which have an automatic transmission feature, you will need to keep the ring count at one.

## Manual reception

1

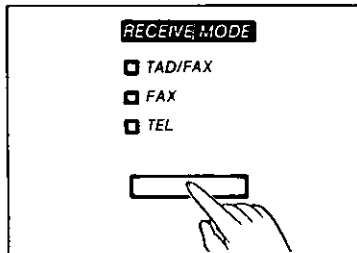

Press the RECEIVE MODE button to set to the TEL mode.

2

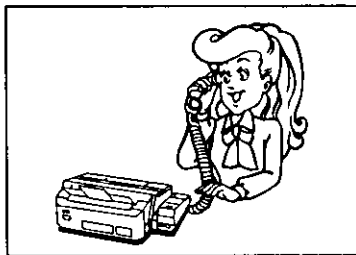

When the phone rings, lift the handset to answer the call.

3

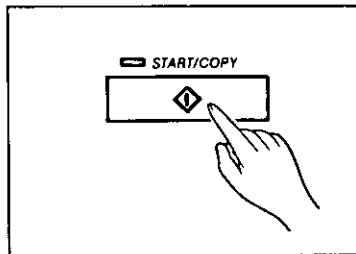

Press the START/COPY button to receive documents, and then place the handset on the cradle.

If you do not place the handset on the cradle after pressing the START/COPY button, the unit automatically calls the other party. For further details, see page 3-20.

### HELPFUL HINTS

- Replace the paper roll with a new one;
  - When the red lines appear on both sides of the recording paper.
  - When the PAPER OUT indicator lights.
  - When the display shows "E-06".The unit cannot receive a document without recording paper. To install recording paper, see page 1-6.
- If the ALARM indicator lights when you close the cover after installing the paper, open the cover and close it firmly again.
- Begin by transmitting the FAX CORRESPONDENCE leaflet (provided) to several of your associates. In this way you can confirm that your unit is functioning correctly and inform them of the procedure for transmitting documents and/or recording voice-message on your unit.

## Manual reception during a telephone conversation

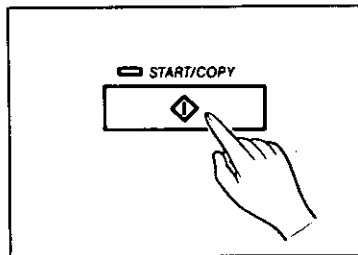

Press the START/COPY button to receive documents during a telephone conversation, and then place the handset on the cradle.

The unit receives documents and the line is automatically disconnected after reception has been completed.

If you wish to resume the conversation after reception, press the MONITOR button while reception is still underway. (For further details, see page 3-20.)

TO CONTINUE FACSIMILE SET UP ONLY, SEE PAGE 3-19.

# ● Making copies

The unit can make a copy. Any transmissible documents can be copied. The unit automatically selects the FINE resolution when copying.

1

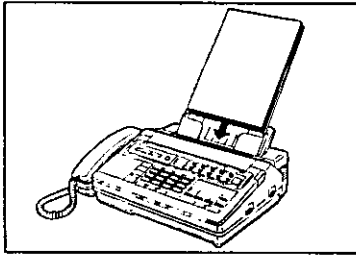

Insert the documents FACE DOWN.

2

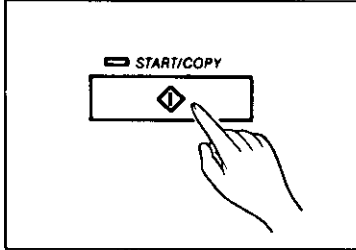

Press the START/COPY button.

The unit feeds the documents and starts copying.

## Interrupting a copy

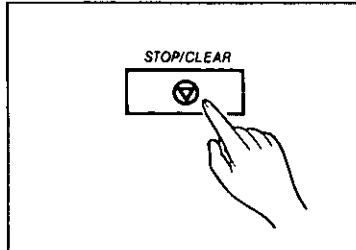

Press the STOP/CLEAR button until a beep sounds.

To eject the document, press the STOP/CLEAR button again.



# CHAPTER 3

## Intermediate Features

<b>User programmable functions</b> .....	3-2
Programming .....	3-3
<b>Programming your logo and fax telephone number identifiers</b> .....	3-4
Programming YOUR LOGO ID .....	3-5
Programming YOUR TELEPHONE NUMBER .....	3-7
<b>Programming phone numbers for automatic dialing</b> .....	3-8
Listing the directory card .....	3-8
Programming phone numbers for one touch dialing .....	3-9
Programming phone numbers for speed dialing .....	3-10
Programming secret phone numbers .....	3-11
Erasing a phone number .....	3-12

### Telephone

<b>Making voice calls using the automatic dialing</b> .....	3-13
---	------

### Answering device

<b>Operating as an answering device</b> .....	3-14
Setup of voice-message and document reception .....	3-15
Playing back recorded voice-messages .....	3-15
Recording after the messages you want to save .....	3-16
Monitoring incoming calls .....	3-16
Recording a memo message .....	3-17
Recording a 2-way conversation .....	3-18

### Facsimile

<b>Transmitting documents using automatic dialer</b> .....	3-19
<b>Voice contact</b> .....	3-20
Initiating voice contact .....	3-20
Receiving a request for voice contact .....	3-20
<b>Transmitting documents to your unit</b> .....	3-21
Leaving a message and transmitting documents on the same call .....	3-21
Transmitting documents with manual operation .....	3-22

# ●User programmable functions

The following functions are user selectable. The most probable choices have been preselected (default), but may be changed as needed.

Code	Function	Default	Reference
#01	SET DATE	(not entered)	Pages 2-2 and 2-3
#02	YOUR LOGO	(not entered)	Pages 3-4 to 3-6
#04	YOUR TELEPHONE NUMBER	(not entered)	Page 3-7
#05	FAX LOGO HEADING	ON	Page 6-2
#06	REMOTE TAD ID	111	Page 4-5
#08	PRIVACY RING ID	333	Page 4-10
#10	JOURNAL AUTO PRINT	ON	Page 5-3
#11	PRINT TX REPORT	OFF	Page 5-5
#12	NETWORK PASSCODE	0000	Page 4-18
#14	TX PASSCODE CHECK	OFF	Page 4-19
#15	RX PASSCODE CHECK	OFF	Page 4-20
#16	POLLING PASSWORD	0000	Page 4-14
#17	FAX TX SPEED	9600BPS	Page 6-2
#18	FAX RX SPEED	9600BPS	Page 6-3
#20	TO NE DETECT	OFF	Page 6-3
#30	RECORDING TIME	VOX	Page 6-4
#31	CPC MODE	A	Page 6-4
#32	TAD/FAX RING COUNT	1 (once)	Page 6-5
#33	FAX RING COUNT	1 (once)	Page 6-5
#34	AUTO RECEIVE TIMER	OFF	Pages 4-12 and 4-13
#40	PRINT JOURNAL		Page 5-4
#41	PRINT TEL LIST		Page 5-6
#42	PRINTER TEST		Page 7-5
#43	PRINT CHARACTER CODE		Page 5-8
#44	PRINT ERROR CODE LIST		Page 5-7
#50	RESET USER PROGRAMMABLE FUNCTIONS (#05 TO #34)		Page 6-6
#9000*	SERVICE DATA SET UP		Page 6-8

For your convenience, please set the following functions (#01~#04) at first.

- #01 SET DATE
- #02 YOUR LOGO
- #04 YOUR TELEPHONE NUMBER

To print out a list of the current settings of the program functions, press the PROGRAM button and then the START/COPY button.

# Programming

To make a function change;

1. Press the PROGRAM button.  
The PROGRAM indicator lights and the display shows "P\_".
2. Press "#", then press the desired code number.  
The display shows the code number entered and the current setting.
3. If the code number pressed is 01 through 34, enter the desired selection and then press the SET button to store the programming in memory.

To correct an error while programming, press the STOP/CLEAR button then correct input.

If the code number selected is 40 through 50, press the START/COPY button to print out selected reports.

4. Press the PROGRAM button again to end setup.

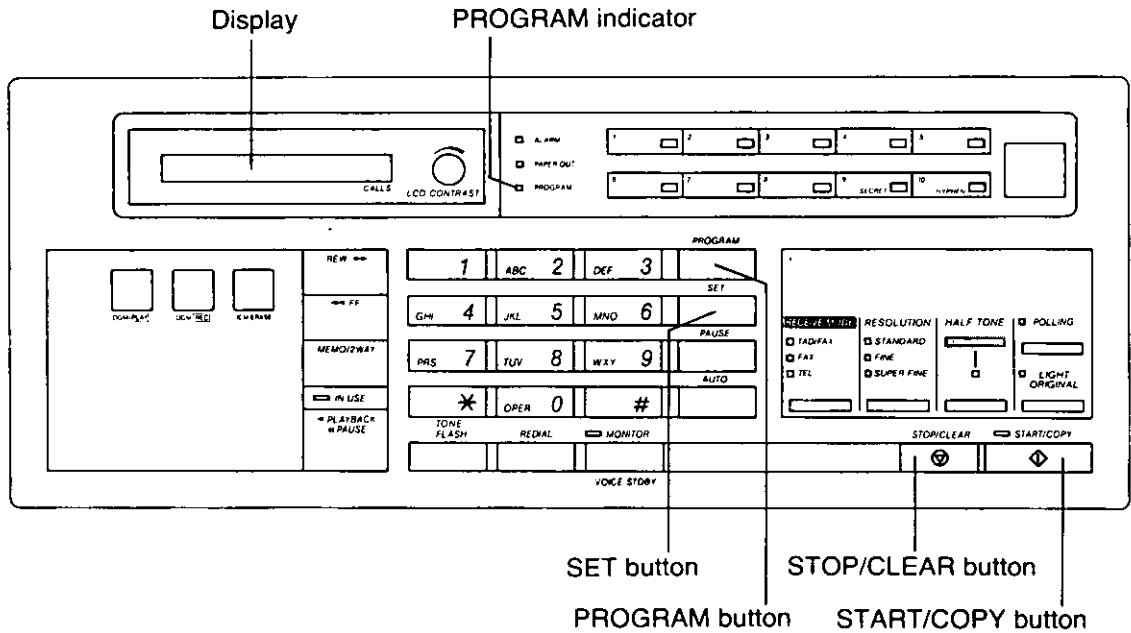

# • Programming your logo and fax telephone number identifiers

**YOUR LOGO :** The LOGO is used to identify fax documents sent by your unit. It may consist of alphanumeric letters and symbols. Usually the LOGO is a company, division or personal name in an abbreviated form. Your programmed LOGO will be printed on the top of all pages transmitted from your unit. Your printed LOGO can be up to 30 digits long.

**YOUR TELEPHONE NUMBER:** Your facsimile telephone number can be programmed into your unit. When you transmit a document, your programmed number will be printed on the top of all pages transmitted from your unit. The unit can hold your phone number up to 20 digits long.

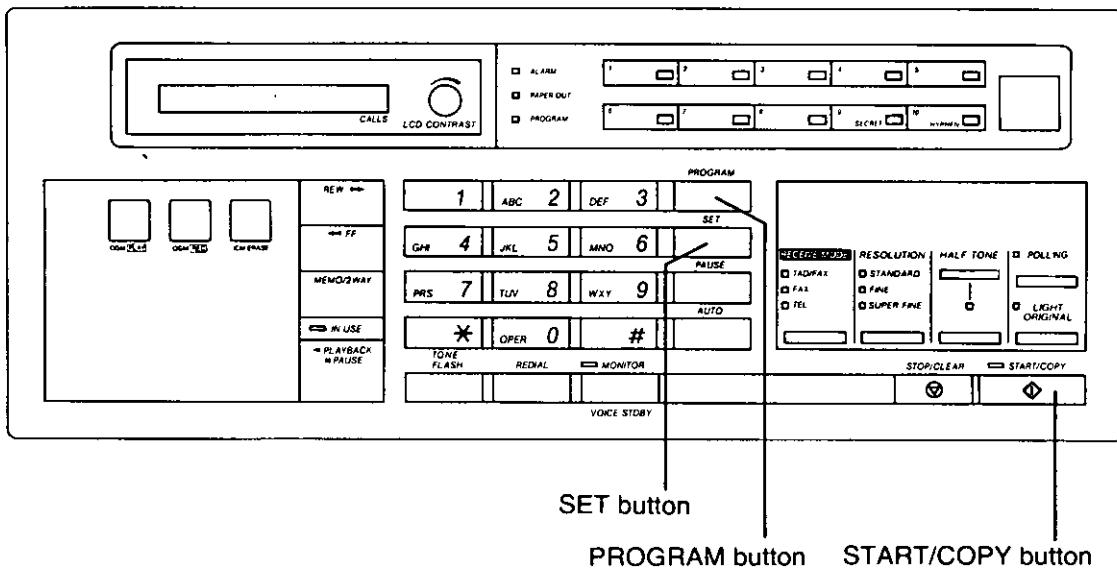
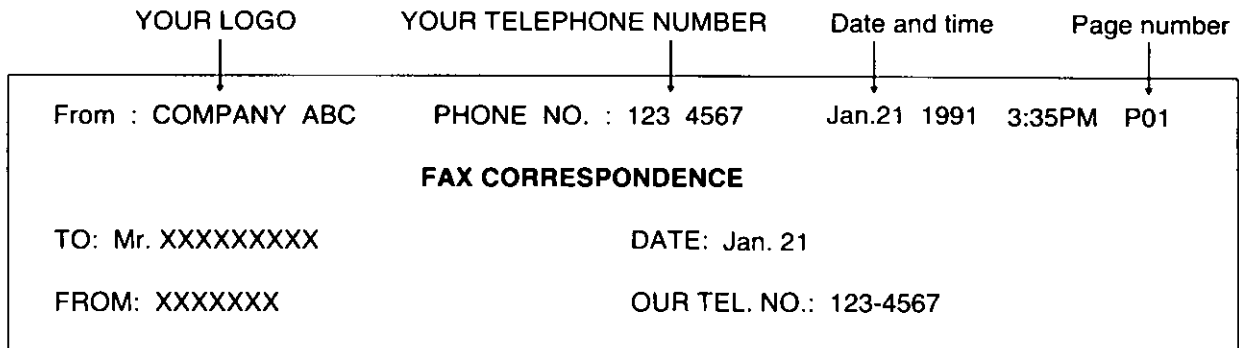

# Programming YOUR LOGO

To enter each character, select the correct code (2 digits) referring to the character code table on page 3-6, and program as shown below.

1

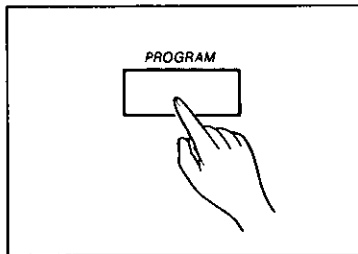

Press the PROGRAM button.

The PROGRAM indicator lights and the display shows "P-\_"

2

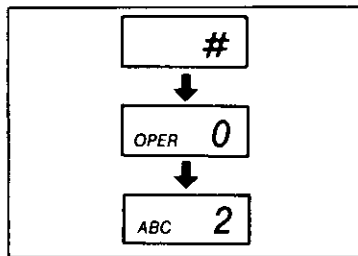

Press "#", then press "02" for YOUR LOGO setting.

The display shows "P-F02".

3

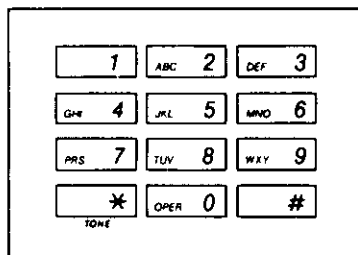

Enter your LOGO by using the dial keypad. The LOGO can be up to 30 characters long.

Refer to character code table on page 3-6.

Example: If you want to program YOUR LOGO as "COMPANY ABC", press "32 44 42 45 30 43 54 01 30 31 32".

To print out your LOGO for confirmation during programming, press the START/COPY button.

4

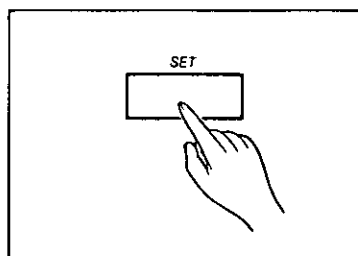

When you have finished, press the SET button to store the programming in memory.

The display shows "P-\_".

5

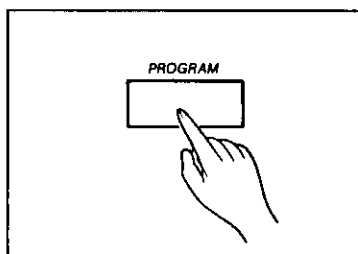

Press the PROGRAM button to end the operation.

The PROGRAM indicator goes out and the display shows the current time.

**Character code table**

Input	Code	Input	Code	Input	Code	Input	Code	Input	Code
(NOTE1)	00	)	10	0	20	A	30	K	40
(space)	01	*	11	1	21	B	31	L	41
!	02	+	12	2	22	C	32	M	42
"	03	,	13	3	23	D	33	N	43
#	04	-	14	4	24	E	34	O	44
\$	05	.	15	5	25	F	35	P	45
%	06	/	16	6	26	G	36	Q	46
&	07	:	17	7	27	H	37	R	47
'	08	;	18	8	28	I	38	S	48
(	09	<	19	9	29	J	39	T	49

Input	Code	Input	Code	Input	Code	Input	Code	Input	Code
U	50	a	60	k	70	u	80	_	90
V	51	b	61	l	71	v	81	'	91
W	52	c	62	m	72	w	82	{	92
X	53	d	63	n	73	x	83		93
Y	54	e	64	o	74	y	84	}	94
Z	55	f	65	p	75	z	85	→	95
=	56	g	66	q	76	[	86	(NOTE2)	96
>	57	h	67	r	77	¥	87		
?	58	i	68	s	78	]	88		
@	59	j	69	t	79	^	89		

NOTE1: Enter "00" to erase all of the characters that have been programmed. (All Clear)

NOTE2: Enter "96" to delete the last character. (Back Space)

You can write down the correct codes for your logo.

					5					10					15
Logo															
Code															
Logo															
Code															
					20					25					30

# Programming YOUR TELEPHONE NUMBER

1

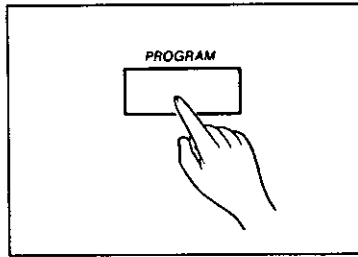

Press the PROGRAM button.

The PROGRAM indicator lights and the display shows "P-\_"

2

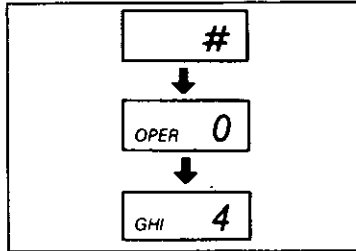

Press "#", then press "04" for YOUR TELEPHONE NUMBER setting.

The display shows "P-F04".

3

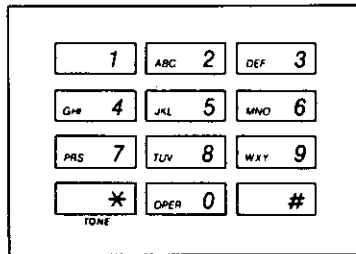

Enter your telephone number by using the dial keypad up to 20 digits long.

Example: If the phone number is "123 4567", press "123", "#", and "4567".

The "#" provides a space.

4

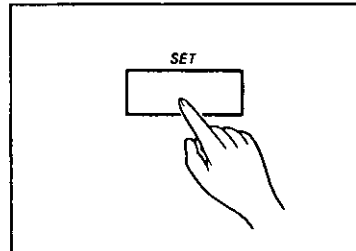

When you have finished, press the SET button to store the programming in memory.

The display shows "P-\_".

5

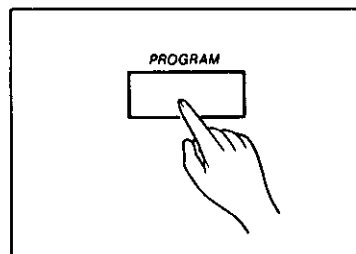

Press the PROGRAM button to end the operation.

The PROGRAM indicator goes out and the display shows the current time.

# ●Programming phone numbers for automatic dialing

The unit's memory allows you to use both one touch dialing (up to 10 phone numbers) and speed dialing (up to 50 phone numbers) for rapid access to your most frequently dialed numbers.

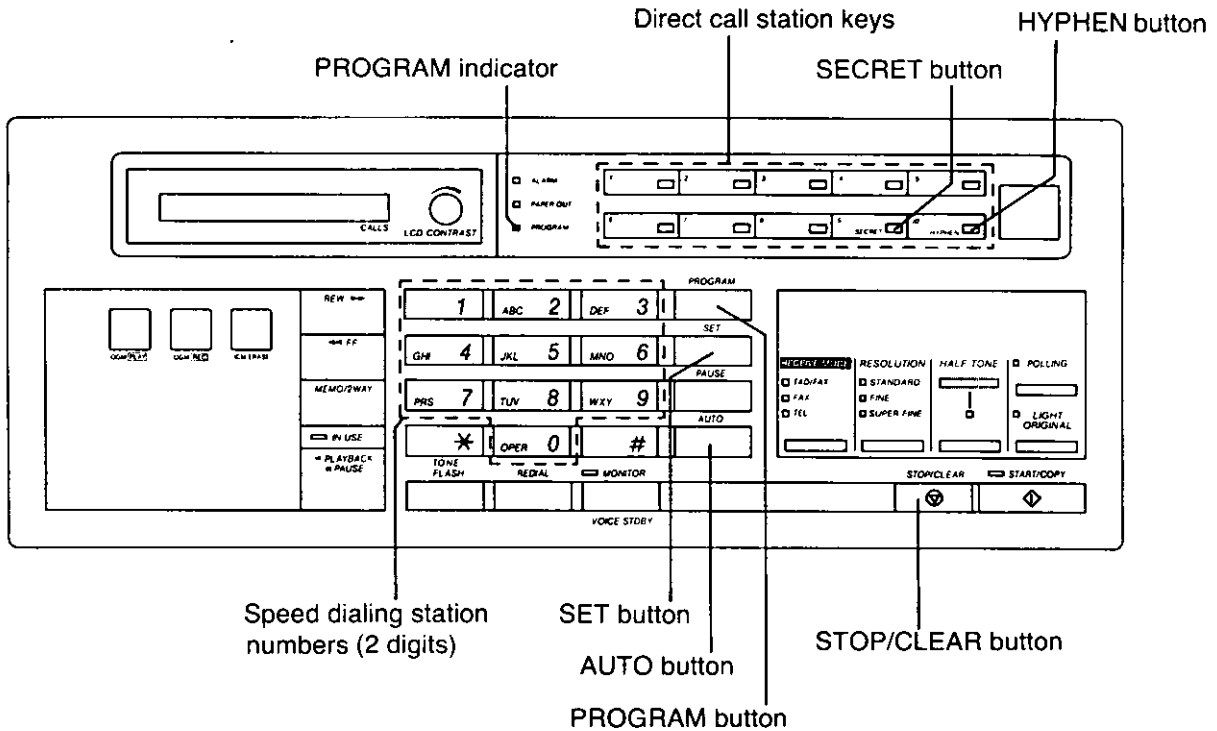

## Listing the directory card

1. Open the cover.
2. Remove the directory card.
3. Write the names (or telephone numbers) that you want to store into memory.

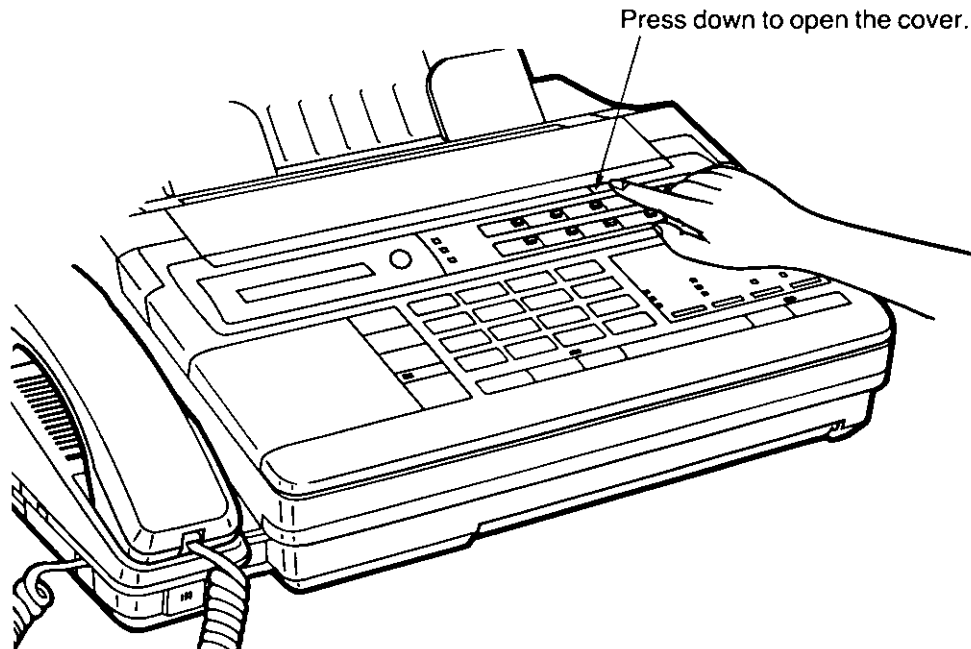



# Programming phone numbers for one touch dialing

This unit is equipped with 10 direct call stations including SECRET and HYPHEN keys, each of which can store a telephone number. Each phone number can be programmed up to 30 digits long. Make sure first whether the DIALING MODE selector is set to TONE or PULSE mode, since the number will be stored in the mode that is set at the time of programming.

1

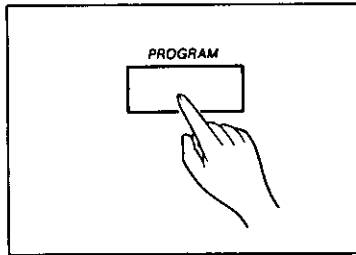

Press the PROGRAM button.

The PROGRAM indicator lights and the display shows "P-\_".

2

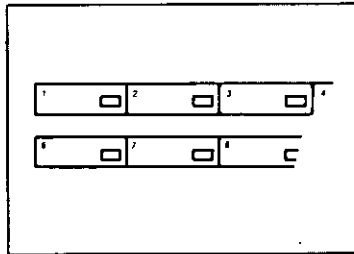

Press one of the direct call station keys where you want to store the phone number.

(e.g. If you select the station key 1, the display shows "P-d01".)

3

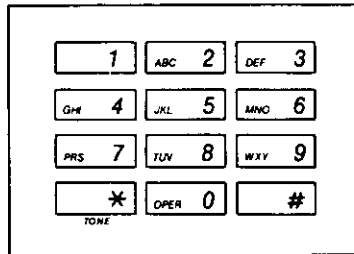

Enter the phone number by using the dial keypad.

If you want to insert a hyphen in the number, press the HYPHEN key during programming. HYPHEN is counted as 2 digits.

4

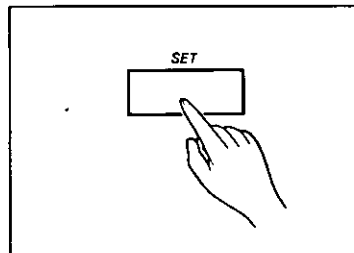

Press the SET button to store the programming in memory.

To program other phone numbers, repeat steps 2 to 4.

5

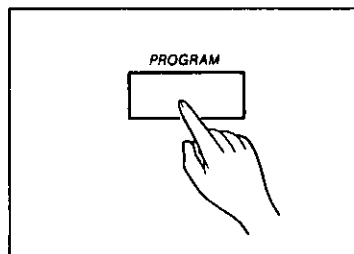

After programming all the numbers, press the PROGRAM button to end the operation.

The PROGRAM indicator goes out and the display shows the current time.

## HELPFUL HINT

- To correct an error while programming, press the STOP/CLEAR button then repeat from step 2. To print out a list of the stored phone numbers, press the PROGRAM button, "#", and "41", then press the START/COPY button.

# Programming phone numbers for speed dialing

The unit is equipped with 50 stations (00 through 49), each of which can store a phone number. Each phone number can be programmed up to 30 digits long.

Make sure first whether the DIALING MODE selector is set to TONE or PULSE mode, since the number will be stored in the mode that is set at the time of programming.

1

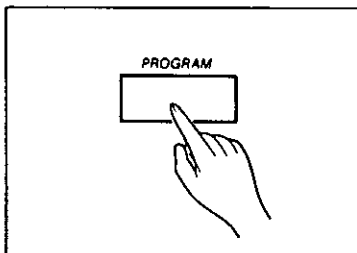

Press the PROGRAM button.

The PROGRAM indicator lights and the display shows "P-\_".

2

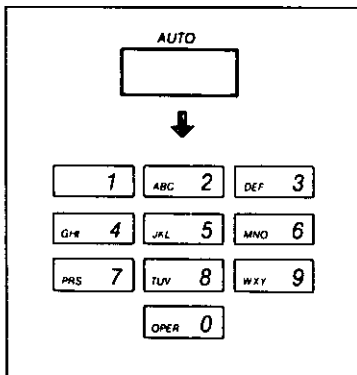

Press the AUTO button, then enter the speed dialing station number at 2 digits (00 through 49) by using the dial keypad.

3

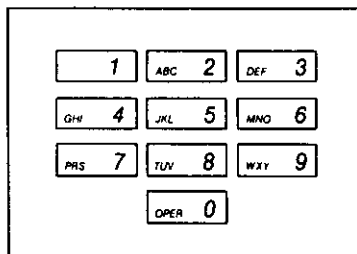

Enter the phone number by using the dial keypad.

If you want to insert a hyphen in the number, press the HYPHEN key during programming. HYPHEN is counted as 2 digits.

4

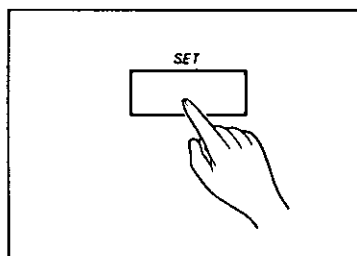

Press the SET button to store the programming in memory.

To program other phone numbers, repeat steps 2 to 4.

5

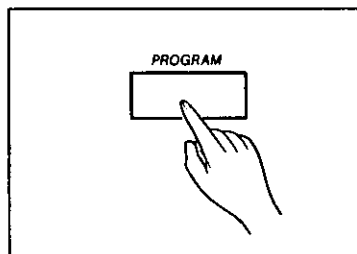

After programming all the numbers, press the PROGRAM button to end the operation.

The PROGRAM indicator goes out and the display shows the current time.

## HELPFUL HINT

- To correct an error while programming, press the STOP/CLEAR button then repeat from step 2.
- To print out a list of the stored phone numbers, press the PROGRAM button, "#", and "41", then press the START/COPY button.

# Programming secret phone numbers

This function is useful for keeping the whole or a portion of a phone number secret. When you print out a list of the stored numbers, this number will not be printed.

1

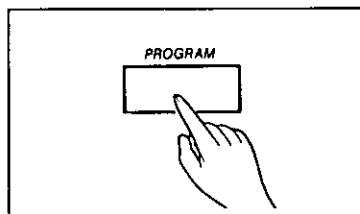

Press the PROGRAM button.

The PROGRAM indicator lights and the display shows "P-\_".

2

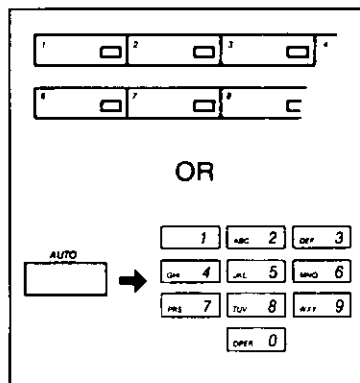

Press one of the direct call station keys.

OR

Press the AUTO button, then enter the speed dialing station number (00 through 49).

3

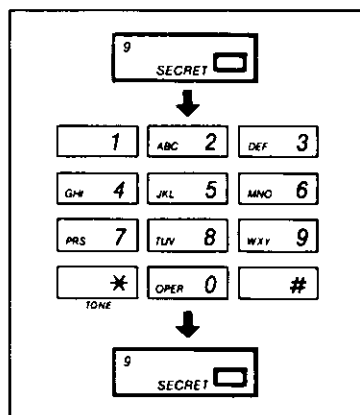

Press the SECRET key and enter the phone number, then press the SECRET key again.

Pressing the SECRET key once counts as 2 digits.

4

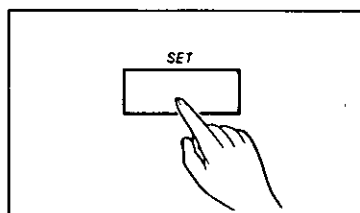

Press the SET button to store the programming in memory.

5

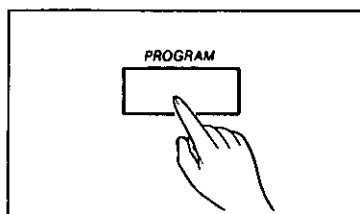

Press the PROGRAM button to end the operation.

The PROGRAM indicator goes out and the display shows the current time.

## HELPFUL HINT

- To correct an error while programming, press the STOP/CLEAR button then repeat from step 2.

# Erasing a phone number

If you wish to erase a phone number programmed into memory, follow the steps below.

1

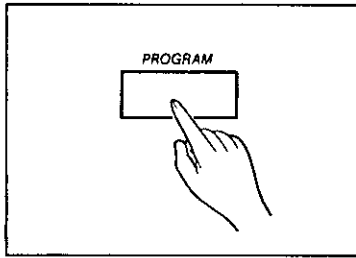

Press the PROGRAM button.

The PROGRAM indicator lights and the display shows "P-\_".

2

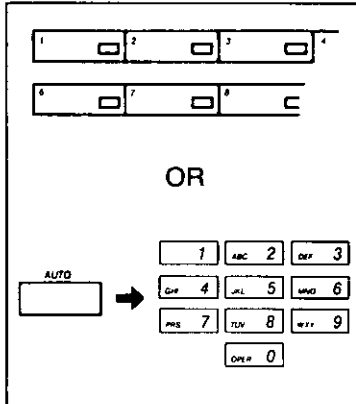

Press the desired direct call station key.

OR

Press the AUTO button, then enter the desired speed dial station number (00 through 49).

3

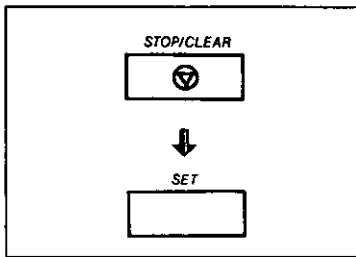

Press the STOP/CLEAR button, then press the SET button.

The number will now be erased. If you wish to erase more than one number, repeat from step 2.

4

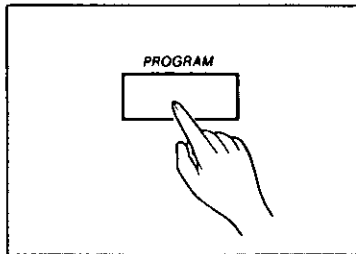

Press the PROGRAM button to end the operation.

The PROGRAM indicator goes out and the display shows the current time.

# •Making voice calls using automatic dialer

## HELPFUL HINT

- The unit's memory allows you to use both one touch dialing (up to 10 phone numbers) and speed dialing (up to 50 phone numbers) for rapid access to your most frequently called numbers.
- Before using these features, make sure that the desired telephone numbers have been stored in memory. See pages 3-8 to 3-12.

1

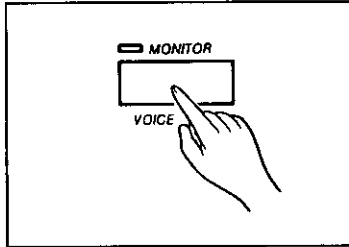

Press the MONITOR button or lift the handset.

2

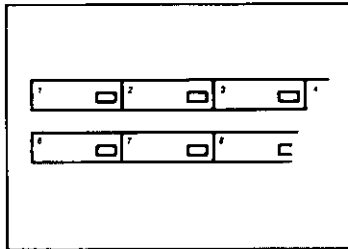

### Using one touch dialing:

Press the desired direct call station key.

OR

OR

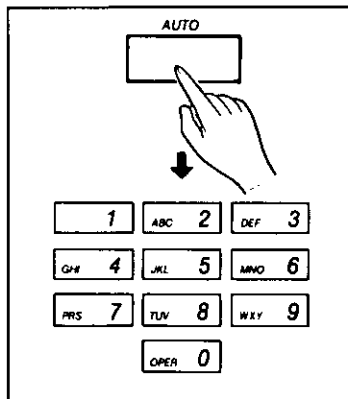

### Using speed dialing:

Press the AUTO button, then press the desired station number (00 through 49) by using the dial keypad.

TELEPHONE SECTION CONTINUED ON PAGE 4-2.

## ●Operating as an answering device

The unit also works as an automatic telephone answering and recording system. The following functions are available as an answering device.

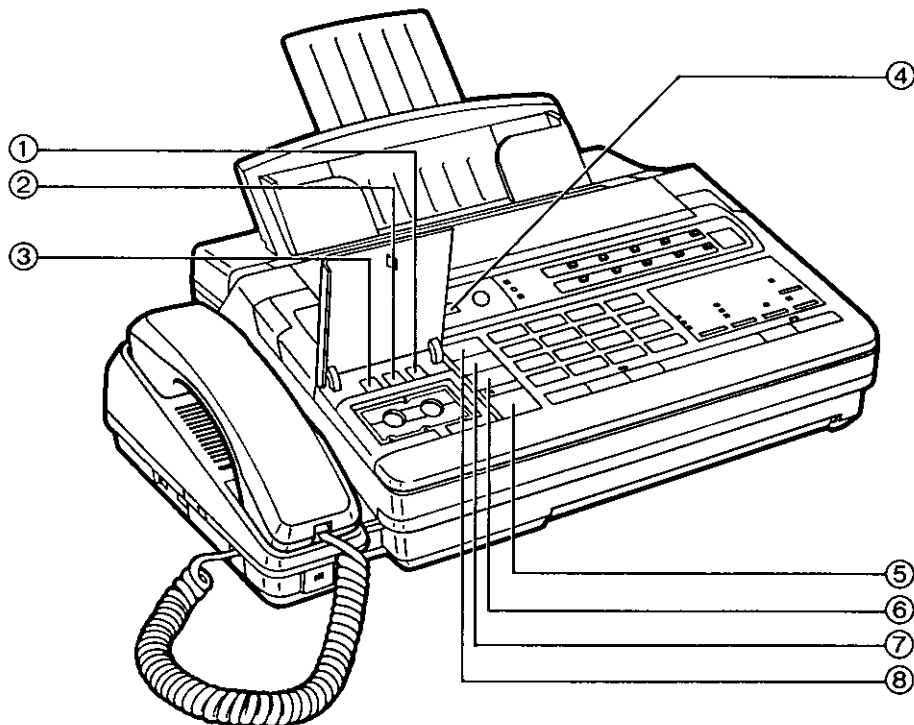

① **Erasing recorded voice-messages:**

After reviewing your messages, press the ICM ERASE button. The messages are erased while the tape is rewind.

The tape can be erased at high speed even if the record-prevention (knock-out) tabs have been removed.

② **Recording your OGM:**

See page 2-7.

③ **Verifying your OGM:**

See page 2-7.

④ **LCD (Liquid Crystal Display):**

The number of recorded voice-messages are shown on the display and the TAD/FAX indicator flashes.

If the power supply has been interrupted the display shows “- -”.

⑤ **Playing back recorded voice-messages:**

Press the PLAYBACK/PAUSE button.

**Stopping the tape (Pause mode):**

Press the PLAYBACK/PAUSE button during playback mode. The tape pauses until you restart it by pressing the PLAYBACK/PAUSE button. The unit does not answer calls automatically while in the pause mode.

⑥ **Recording a memo message:**

See page 3-17.

**Recording a 2-way conversation:**

See page 3-18.

⑦ **Forwarding the tape quickly:**

Press the FF (Fast Forward) button.

⑧ **Rewinding (Resetting) the tape quickly:**

Press the REW (Rewind) button.

# Setup of voice-message and document reception

1

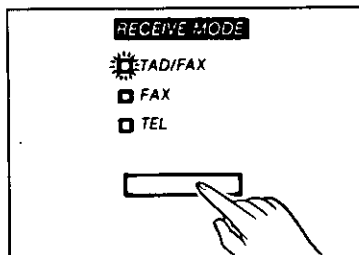

Press the RECEIVE MODE button until the TAD/FAX indicator lights.

2

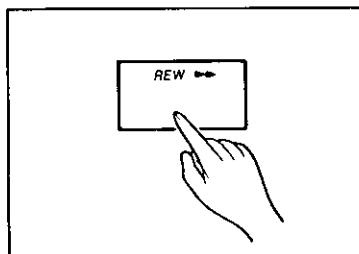

Press the REW button to record messages from the beginning of the tape.

When a call is received, the unit answers the call and begins playback of your OGM. The unit automatically distinguishes between voice and fax calls, and then functions as an answering device and/or a facsimile.

## HELPFUL HINT

- The recording time for incoming messages can be set to VOX (unlimited) or 1 MIN (1 minute). It is preset to VOX. To change the recording time, see page 6-4.

## Playing back recorded voice-messages

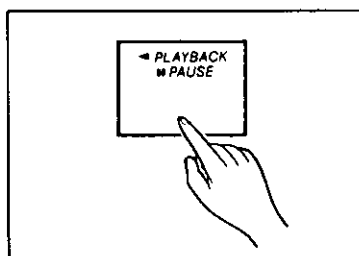

Press the PLAYBACK/PAUSE button.

### One Touch Operation:

The unit plays all the recorded messages when the PLAYBACK/PAUSE button is pressed. At the end of the last message the tape stops, and 3 beeps are heard. After 7 seconds, the unit resets itself to the TAD/FAX mode. All calls are saved automatically.

## Recording after the messages you want to save

New incoming messages will be automatically stored after the last message. If you wish to store incoming messages after your saved messages, perform the following steps.

1

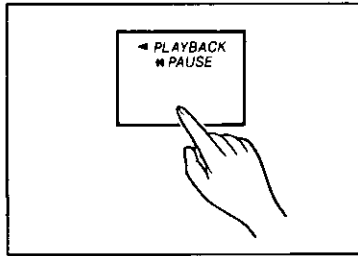

Press the PLAYBACK/PAUSE button to play back the tape to the end of the messages you want to save.

2

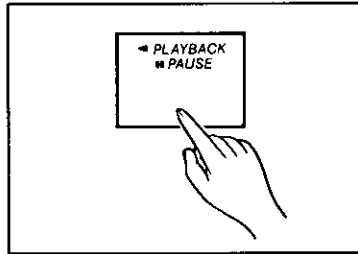

Press the PLAYBACK/PAUSE button again to stop the tape (Pause mode).

The IN USE indicator flashes.

3

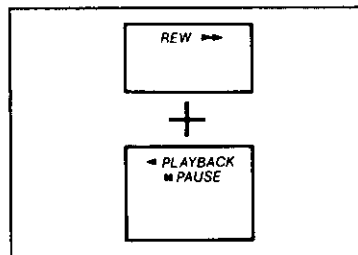

Press the REW and PLAYBACK/PAUSE button together.

New calls will be recorded after the messages you have saved.

## Monitoring incoming calls

While an incoming message is being recorded, you can monitor it through the built-in speaker. Adjust the sound level using the VOLUME control.

You can talk to the caller directly by simply lifting the handset. The unit stops recording automatically.



# Recording a memo message

If you are going out and you want to leave a private message for someone, you can record a voice memo in the unit. This can then be played back either directly or remotely, exactly like any other incoming message.

**1**

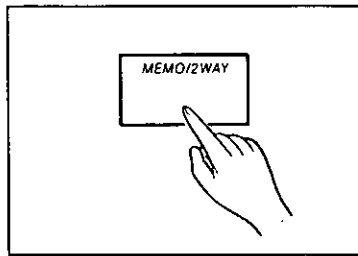

Press the MEMO/2 WAY button until a beep is heard.

The IN USE indicator lights.

**2**

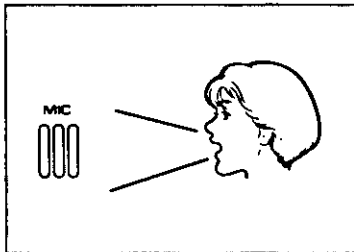

Speak toward the microphone from approximately 20 cm (8 inches) away.

**3**

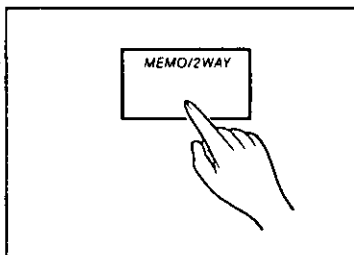

When the recording is finished, press the MEMO/2 WAY button again.

The IN USE indicator goes out.

# Recording a 2-way conversation

While speaking with someone on the telephone, you can record your conversation. Many states have imposed regulations on the manner in which 2-way telephone conversations may be recorded. Consult your local telephone company for further information.

1

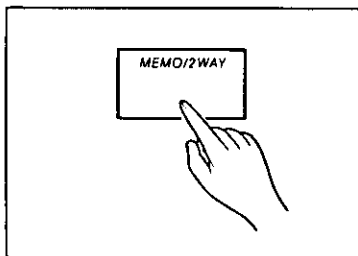

During your conversation, press the MEMO/2 WAY button until a beep is heard.

The IN USE indicator lights.

2

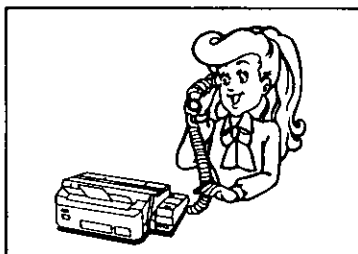

Continue your conversation.

A beep sounds every 15 seconds to notify the caller that the conversation is being recorded.

3

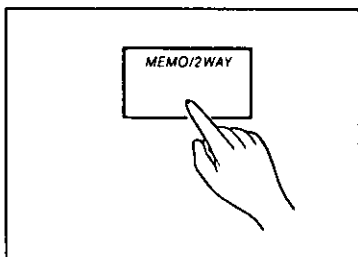

To stop recording, press MEMO/2 WAY button again.

The IN USE indicator goes out.

ANSWERING DEVICE SECTION CONTINUED ON PAGE 4-4.

# •Transmitting documents using automatic dialer

You can transmit documents using automatic dialer. Before using these features, make sure that the desired telephone numbers have been stored in memory. For programming of phone numbers, see pages 3-8 to 3-12.

1

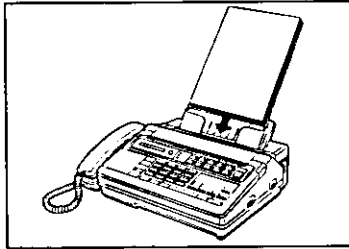

Insert the documents FACE DOWN.

2

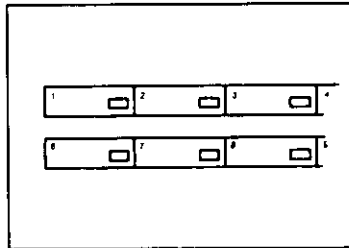

**Using one touch dialing:**

Press the desired direct call station key.

The unit dials and transmits the documents automatically.

OR

OR

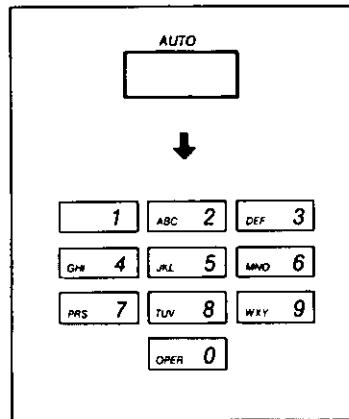

**Using speed dialing:**

Press the AUTO button, then press the desired station number (00 through 49) by using the dial keypad.

The unit dials and transmits the documents automatically.

**Automatic redialing:**

If there is no answer or the line is busy, the unit will automatically redial the number up to 6 times within 10 minutes. To cancel automatic redialing, press the FLASH button or the STOP/CLEAR button.

# ●Voice contact

## Initiating voice contact

While you are transmitting or receiving a document, you may wish to speak to the other party. If the other party's unit is equipped with a voice contact feature, you can initiate voice contact and notify the other party that you wish to speak after the transmission/reception is completed. The other party's fax will emit a distinctive ring that indicates that a voice conversation is required. This saves extra expense and time of making a subsequent telephone call to discuss information sent over the fax.

1

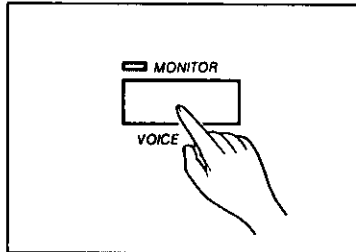

Press the MONITOR button or lift the handset while transmitting or receiving the documents.

2

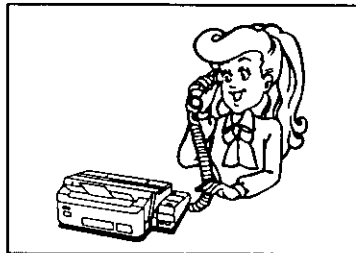

When the other party answers, start speaking using the handset.

If you initiate voice contact while transmitting documents, you can speak after all the documents have been transmitted.

If you initiate voice contact while receiving documents, you can speak after receiving the current page of the documents.

## Receiving a request for voice contact

If the other party initiates voice contact during transmission or reception, your unit will emit a distinctive ring after the fax is completed.



When the unit rings, lift the handset and start speaking.

### HELPFUL HINT

- If you do not answer within 10 seconds after hearing several rings indicating the request for voice contact, one of the followings occurs:
  - When the unit is in the TAD/FAX mode, it plays back your OGM and records the voice-message on the tape.
  - When the unit is in the FAX mode, the line is disconnected.
  - When the unit is in the TEL mode, the line is disconnected.

# •Transmitting documents to your unit

## Leaving a message and transmitting documents on the same call

When the unit is in the TAD/FAX mode, your caller can follow the steps below to leave a message and send documents.

### From a touch tone phone:

1

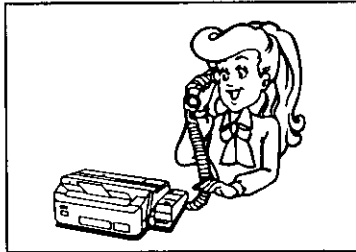

Your caller may call your unit and then leave you a message after the long beep following your OGM.

2

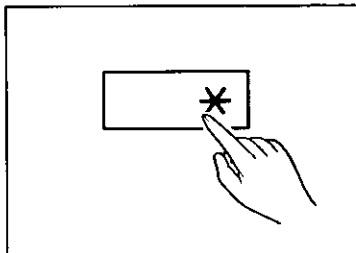

When their message is finished, they may press "\*" to change the unit to the fax mode and then start transmission upon hearing the fax tone.

### From a rotary (pulse) phone:

If the calling facsimile machine has a voice contact function, your caller can leave a message after transmitting documents to your facsimile.

1

Your caller may call your unit and then press the mute button or cover the mouthpiece of his/her handset to change the unit to the fax mode during OGM.

Start transmission after hearing the fax tone.

Make a call reservation (e.g. lift the handset) during transmission. The unit plays back the OGM again.

2

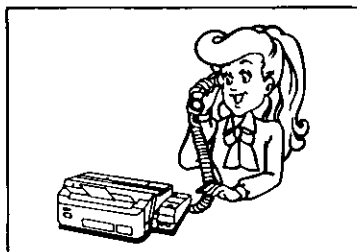

Leave your message after the long beep following the OGM.

# Transmitting documents with manual operation

## From a touch tone phone:

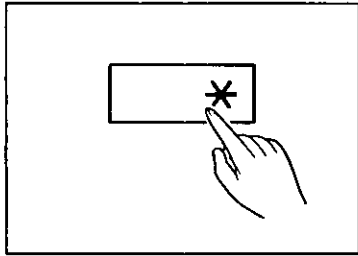

Call your unit, then press “\*” to change the unit to the fax mode.

Start transmission upon hearing the fax tone.

## From a rotary (pulse) phone:

Call your unit, then press the mute button or cover the mouthpiece of your handset to change the unit to the fax mode during the OGM.

Start transmission upon hearing the fax tone.

FACSIMILE SECTION CONTINUED ON PAGE 4-12.

# CHAPTER 4

## Advanced Features

### Telephone

TONE button (Temporary tone dialing) .....	4-2
FLASH button .....	4-2
Combination dialing.....	4-2
PAUSE button.....	4-3

### Answering Device

<b>Operating as an answering device from a remote phone</b> .....	4-4
Toll saver .....	4-4
Summary of remote control functions .....	4-4
Programming a REMOTE TAD ID number for remote operation .....	4-5
Message playback .....	4-6
Newly recorded messages playback (Memory playback).....	4-6
Back space and skip forward .....	4-7
Recording a marker message .....	4-7
Resetting the tape for future messages .....	4-8
Room monitor .....	4-8
Re-recording an outgoing message .....	4-9
Skipping the OGM for ICM recording .....	4-9
<b>Calling with privacy ring</b> .....	4-10
Programming the PRIVACY RING ID .....	4-10
Calling with the privacy ring code.....	4-11

### Facsimile

<b>Auto receive timer</b> .....	4-12
<b>Polling</b> .....	4-14
Setting the polling password .....	4-14
preparation for being polled .....	4-15
Polling another unit .....	4-16
<b>Network communication</b> .....	4-17
Programming the network passcode.....	4-18
Turning the TX passcode check on.....	4-19
Turning the RX passcode check on .....	4-20

## Telephone

### TONE button (Temporary tone dialing)

This function is useful only when your line has rotary pulse dial service. Pressing the TONE (\*) button will allow you to change from pulse to tone mode during a dialing operation, and enter special tones and codes to operate your answering machine, electronic banking services and other special services.

"TONE" can be programmed into memory with the telephone numbers.

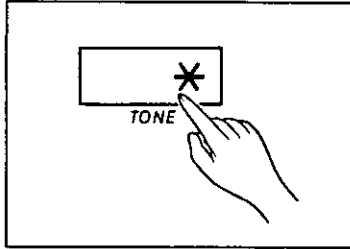

Press the TONE (\*) button.

When you hang up, the unit automatically returns to pulse mode.

"TONE" can be stored in memory in the same way as explained on pages 3-8 to 3-12.

Pressing the TONE button counts as 1 digit while programming.

### FLASH button

The FLASH button is used to access some of the features of your host PBX (Private Branch Exchange).

For further details, please see a brochure issued by your PBX supplier.

#### **Using the FLASH button:**

Press the FLASH button briefly when required.

- "FLASH" can be stored in memory in the same way as explained on pages 3-8 to 3-12.
- Pressing the FLASH button counts as 1 digit while programming.

### Combination dialing

The following combination of dialing methods can be used.

- Manual dialing and automatic dialing
- Pulse and Tone dialing
- Plural memory stations



# PAUSE button

The PAUSE button is used in a dial sequence to access an outside line. Pressing the PAUSE button makes a dialing delay.

## Using the PAUSE button

Example: Line access number 9

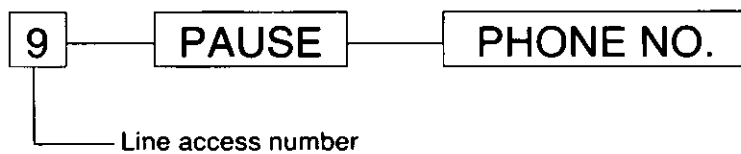

- “PAUSE” can be stored in memory in the same way as explained on pages 3-8 to 3-12.
- Pressing the PAUSE button counts as 1 digit while programming.

# ●Operating as an answering device from a remote phone

You can retrieve the incoming messages and re-record your outgoing message from a remote location with a touch tone telephone.

The following features are available on this unit.

- Message playback
- Newly recorded message playback (Memory Playback)
- Back space and skip forward
- Recording a marker message
- Resetting the tape for future messages
- Room monitor
- Re-recording the OGM (outgoing message)
- Skipping the OGM for ICM (incoming message) recording

These operations are available only in TAD/FAX mode. If your unit is in the TEL mode, call your unit and wait for 15 rings. The unit will switch to the TAD/FAX mode.

## Toll saver

When you call the unit from a remote location, the number of rings tells you if there are any new voice-messages.

If the unit answers on the 1st ring, there is at least one new message recorded.

If the unit answers on the 3rd ring, there are no new messages recorded.

Hang up immediately when you hear the 2nd ring. The 2nd ring indicates that there are no new messages. This will save you the toll charge for the call.

The toll saver function works only when TAD/FAX RING COUNT is set to the Toll Saver position. See page 6-5.

## Summary of remote control functions

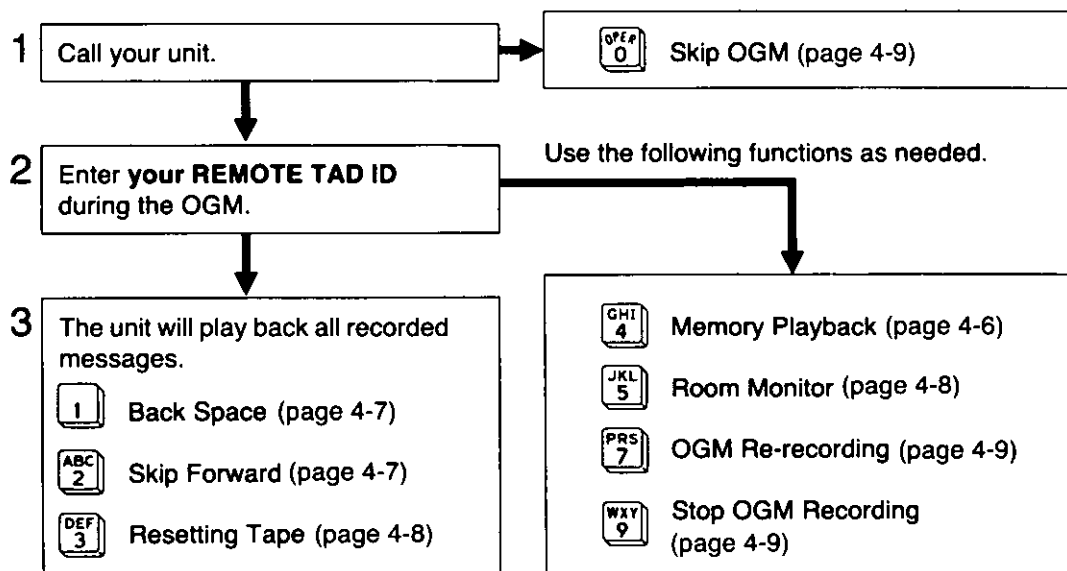

# Programming a REMOTE TAD ID number for remote operation

The REMOTE TAD ID number prevents unauthorized persons from accessing your unit and listening to your messages. The REMOTE TAD ID is preset to 111. If you wish to change the number, you can choose any number from "111" to "999" except numbers including "0".

For proper operation, make sure that the REMOTE TAD ID number is different from your PRIVACY RING ID number.

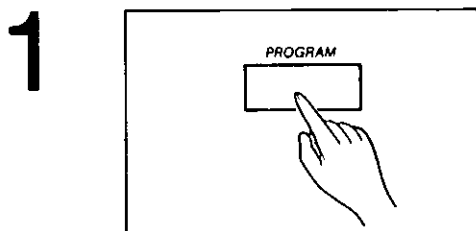

Press the PROGRAM button.

The PROGRAM indicator lights and the display shows "P-\_".

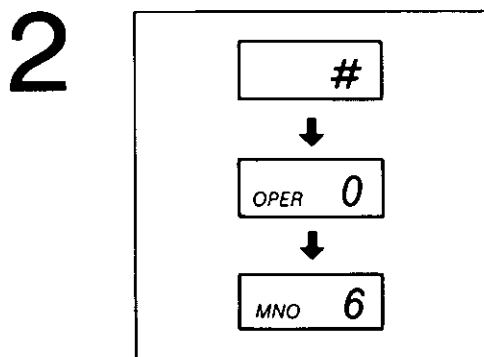

Press "#", then press "06" for REMOTE TAD ID setting.

The display shows "P-F06 111".

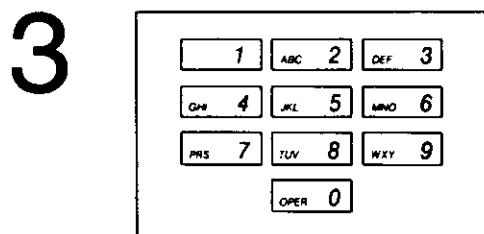

Enter the desired REMOTE TAD ID using the dial keypad.

To correct an error, press the STOP/CLEAR button then correct input.

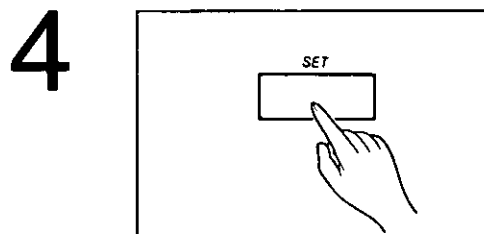

Press the SET button to store the programming in memory.

The display shows "P-\_".

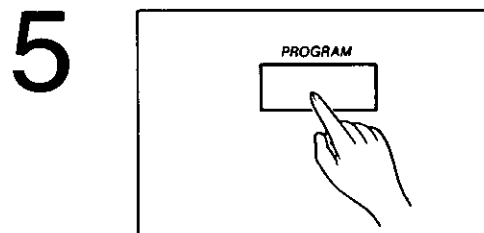

Press the PROGRAM button to end the operation.

The PROGRAM indicator goes out.

## HELPFUL HINTS

- You should not use codes which contain zero (0) since this causes the unit to skip the OGM. (For example, 200, 502 etc.)
- We recommend that you do not use seven (7) as a code number, since this number is used as the OGM rerecording command for remote operations.

# Message playback

You can listen to the recorded messages from a remote location.

1

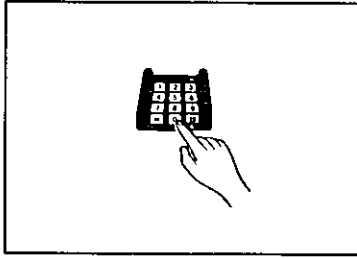

Call your unit.

2

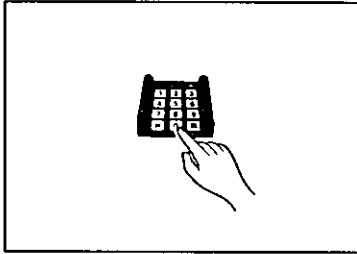

Dial your REMOTE TAD ID while the OGM is playing.

A long beep and a short beep(s) will sound. Short beep(s) indicate(s) the number of recorded messages(s) up to 8 times. Even if 9 or more calls are recorded, a short beep sounds 8 times.

3

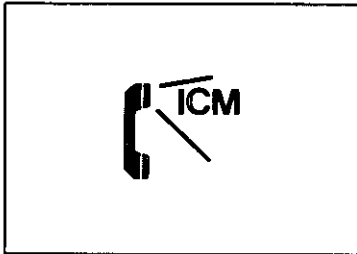

The unit rewinds the tape and plays back the message(s) recorded.

3 beeps will be heard indicating the end of the messages. After hanging up, all the recorded messages are saved and the unit is ready to record further messages.

## Newly recorded messages playback (Memory playback)

It is possible to skip over the recorded messages you have already heard and to play back only new messages.

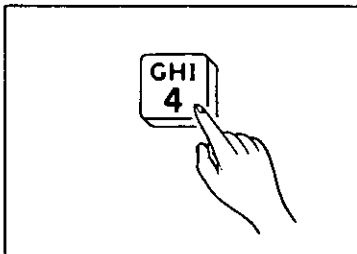

Press "4" immediately after hearing the beeps that indicate the number of recorded messages.

The unit plays back the new messages. Even during the playback of previously heard messages, you can skip to the new messages by pressing "4".

# Back space and skip forward

While listening to the recorded messages, you can rewind or forward the tape.

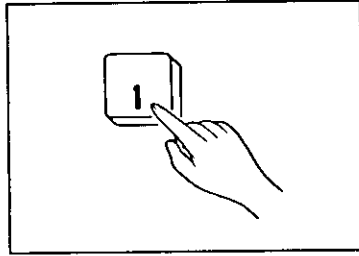

To rewind, press "1".

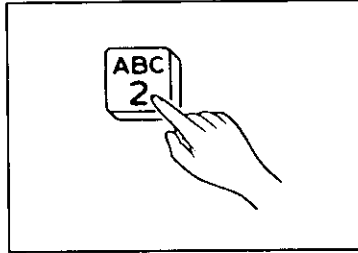

To fast forward, press "2".

## HELPFUL HINT

- The maximum length of message to be rewound or forwarded by one press is approximately 15 seconds. So you may have to press "1" or "2" several times to rewind or forward the tape to the desired position.

# Recording a marker message

After playing back the recorded messages, you can record your new message on the same call. When replay is finished, wait for 3 beeps indicating the end of the last message. Then wait about 10 seconds for another 2 beeps indicating that the tape is ready for recording.

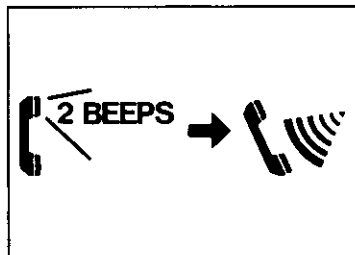
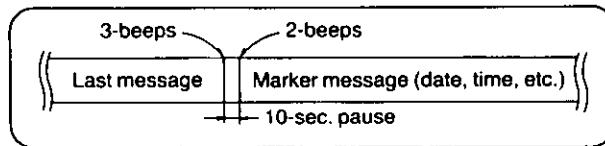

Leave your message after the last 2 beeps.

Hang up when finished. The marker message is recorded after the last message on the tape.

# Resetting the tape for future messages

After listening to the recorded messages, you can reset the tape and record future messages from the beginning of the tape.

**After all the messages have been played back or even while they are being played;**

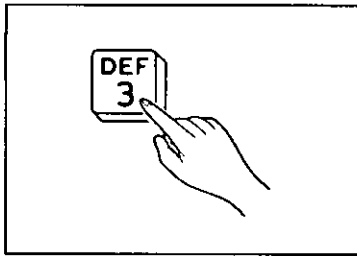

Press "3", then hang up.

The unit rewinds the tape to the beginning. Future messages will be recorded and the previously recorded messages are lost.

**If you have used Memory Playback;**

1

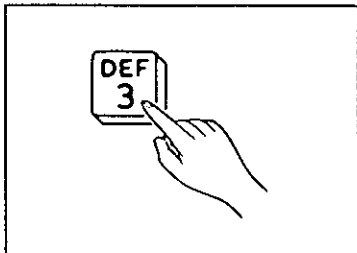

Press "3".

The unit rewinds the tape to the beginning of the newly recorded messages, then beeps.

2

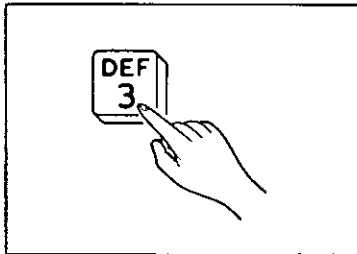

Press "3" again after hearing the beep.

The unit rewinds the tape to the beginning of the previously recorded messages.

**If you have reset the tape by mistake;**

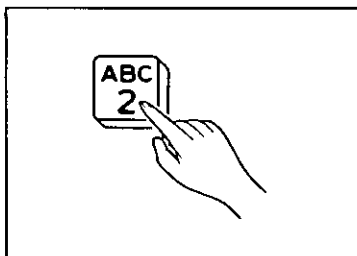

Press "2" after the tape has been reset.

One beep sounds.

The unit advances the tape to the end of the recorded messages.

## Room monitor

You can monitor the sound in the room where the unit is installed for about 30 seconds.

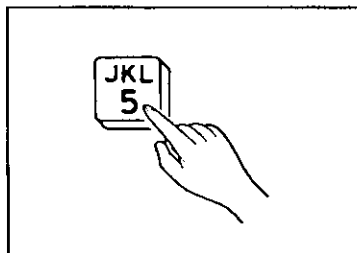

Press "5" to monitor the room sounds after hearing the beeps that indicate the number of recorded messages.

You can hear the room sounds for 30 seconds after one beep. If you wish to continue monitoring, press "5" again within 10 seconds after hearing one beep.

# Re-recording an outgoing message

You can change the content of your OGM from a remote telephone.

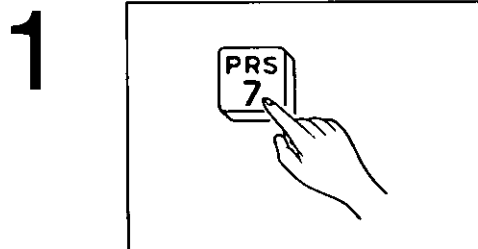

Press "7" to start re-recording after hearing the beeps that indicate the number of recorded messages.

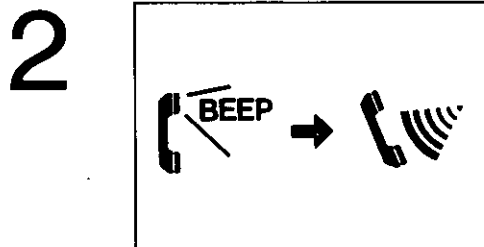

After hearing a long beep, speak clearly and loudly for up to 16 seconds.

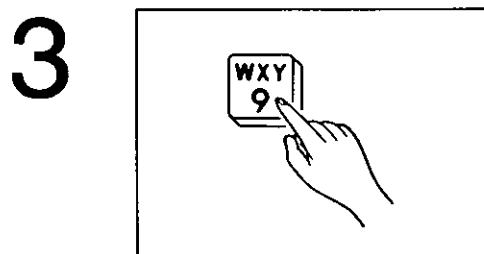

When you finish, press "9".

The new OGM is played back to confirm the change.

## HELPFUL HINT

- If you pause for over 2 seconds while recording, the unit beeps and stops the OGM recording. In this case, repeat from step 1 within 10 seconds.

# Skipping the OGM for ICM recording

Callers can leave a message on your unit without listening to your OGM.

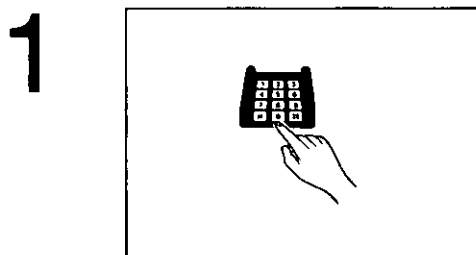

**Instructions for caller:**  
Call your unit.

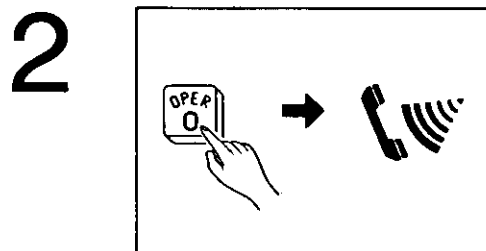

Press "0" while the OGM is playing.

After hearing a long beep, speak clearly and loudly to leave your message.

# •Calling with privacy ring

## HELPFUL HINTS

- This feature eliminates interruptions caused by unwanted calls. Only callers with a passcode can activate a distinctive tone during the playing of your OGM to notify you of a priority call.
- This feature only works when your unit is in the TAD/FAX mode.
- Entering a unique 3-digit code is required to activate this feature. Issue your code to those callers with priority status. All other calls will be routed to the answering system, unless you pick up the handset.

## Programming the PRIVACY RING ID

The unit provides PRIVACY RING ID "333" as default setting. If you want to change the default setting, follow the steps below.

1

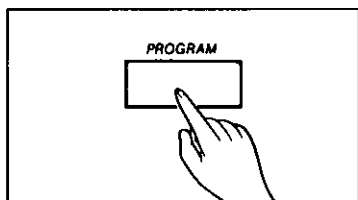

Press the PROGRAM button.

The PROGRAM indicator lights and the display shows "P-\_".

2

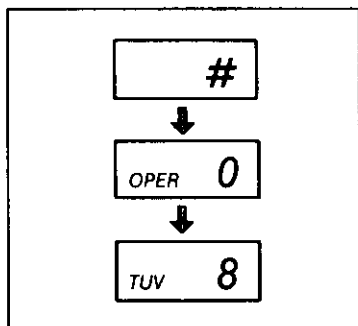

Press "#", then press "08" for PRIVACY RING ID setting.

The display shows "P-F08 333".

3

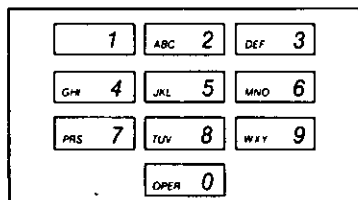

Enter the desired 3-digit number as new PRIVACY RING ID using the dial keypad.

To correct an error, press the STOP/CLEAR button then correct input.

4

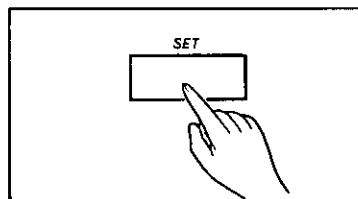

Press the SET button to store the programming in memory.

The display shows "P-\_".

5

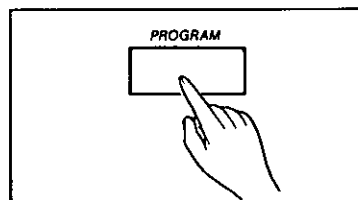

Press the PROGRAM button to end the operation.

The PROGRAM indicator goes out.

## HELPFUL HINTS

- You should not use codes which contain zero (0) since this causes the unit to skip the OGM. (For example, 200, 502, etc.)
- We recommend that you do not use seven (7) as a code number, since this number is used as the OGM rerecording command for remote operations.



# Calling with the privacy ring code

1

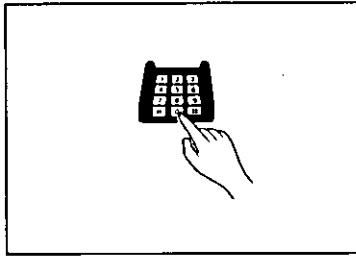

Call the unit with a touch tone telephone.

2

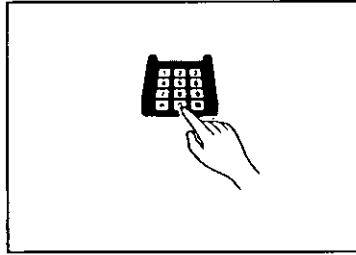

Enter the PRIVACY RING ID during the OGM or the ICM recording mode.

The unit rings with a distinctive tone for 30 seconds and goes into the ICM recording mode if nobody answers.

To repeat this process, press the ID number again during the ICM recording mode.

# •Auto receive timer

This feature allows you to set the unit in the auto receiving mode (TAD/FAX or FAX) for the desired time automatically. For example, you may wish to use the unit in the TEL mode during the work days and switch to the TAD/FAX or FAX mode during the evenings.

The TAD/FAX or FAX mode is automatically turned ON or OFF at the preprogrammed time.

To activate this function, use AUTO RECEIVE TIMER in the programming functions.

1

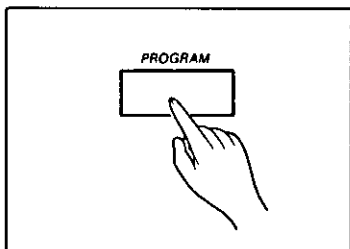

Press the PROGRAM button.

The PROGRAM indicator lights and the display shows "P-\_".

2

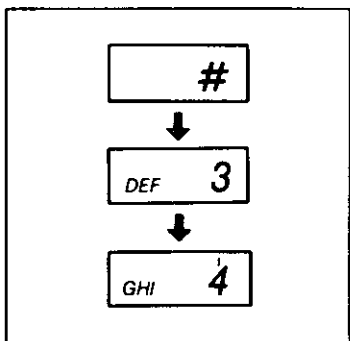

Press "#", then press "34" for AUTO RECEIVE TIMER setting.

The display shows "P-F34 2".

Setting selections are ;

1: Turning the auto receive timer ON.

2: Turning the auto receive timer OFF.

3

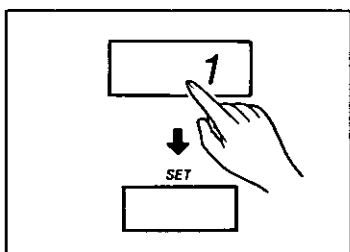

Press "1" to turn the auto receive timer on, then press the SET button.

The display shows "AM P-F34 12-00".

4

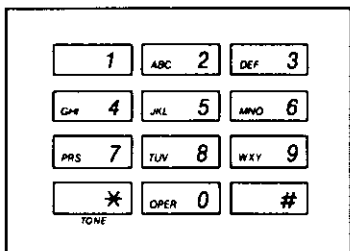

Enter the ON time using 4 digits.

For example, if ON time is 5:00PM, press "0 5 0 0", then press "\*" to select PM.

"PM" or "AM" is shown alternately by each pressing of "\*".

To correct an error, press the STOP/CLEAR button then correct input.

5

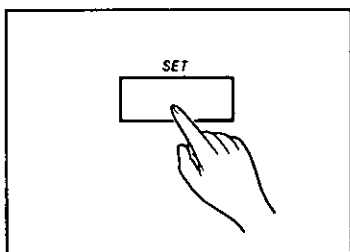

Press the SET button.

The display shows "P-F34 1".

Setting selections are;

1: TAD/FAX mode

2: FAX mode

# 6

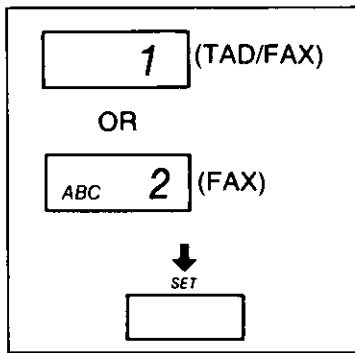

Press "1" or "2" to select the desired receiving mode, then press the SET button.

The display shows "AM P-F34 12-00".

# 7

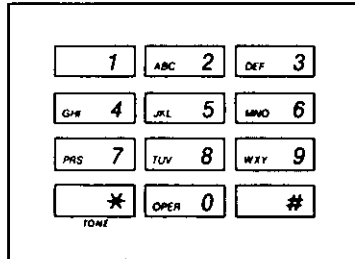

Enter the OFF time using 4 digits.

For example, if OFF time is 9:00AM, press "0 9 0 0", then press "\*" to select AM. "PM" or "AM" is shown alternately by each pressing of "\*".

To correct an error, press the STOP/CLEAR button, then correct input.

# 8

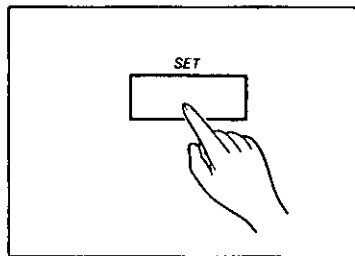

Press the SET button.

The display shows "P-F34 3".

Setting selections are;

- 1: TAD/FAX mode
- 2: FAX mode
- 3: TEL mode

# 9

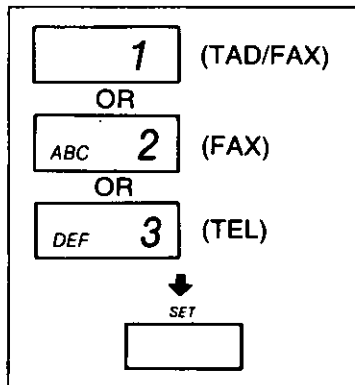

Press 1, 2 or 3 to select the desired receiving mode after the auto receiving mode is turned off, then press the SET button.

The display shows "P-\_".

# 10

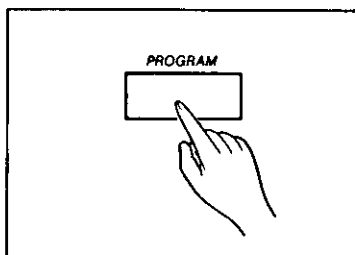

Press the PROGRAM button to end the operation.

The PROGRAM indicator goes out.

# ●Polling

Polling means that you call another facsimile machine (we call it “polled machine”) to retrieve a document. Polling also lets you place documents in the unit that will be “retrieved” only at the request of a calling machine. The receiving unit incurs any long distance telephone charges since the polling unit initiates the call.

## Setting the polling password

### HELPFUL HINTS

- In order to prevent an unauthorized machine from retrieving a specific document such as of a confidential nature, you can program a unique code (password) in your unit. If the passwords in the polling unit and polled unit do not match, any transaction will not take place.
- The polling using a password is effective only between Quasar compatible facsimile machines (e.g. PAX200H, PAX400H, PAX600H).

1

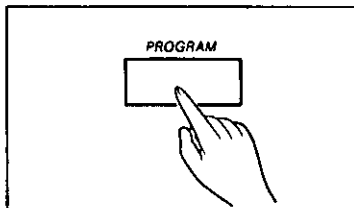

Press the PROGRAM button.

The PROGRAM indicator lights and the display shows “P-”.

2

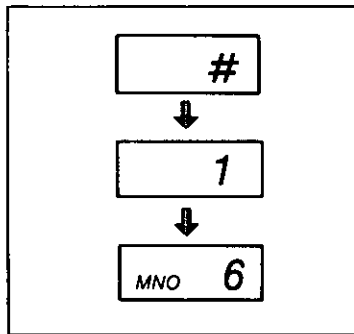

Press “#”, then press “16” for POLLING PASSWORD setting.

The display shows “P-F16 0000”.

3

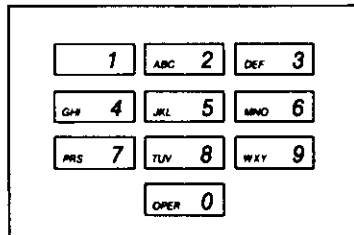

Enter your polling password of 4 digits using the dial keypad.

You can choose among numbers “0001” through “9999” as the password. To correct an error, press the STOP/CLEAR button then correct input.

4

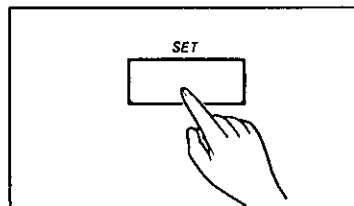

Press the SET button to store the programming in memory.

The display shows “P-”.

5

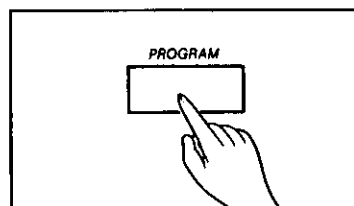

Press the PROGRAM button to end the operation.

The PROGRAM indicator goes out.

### HELPFUL HINT

- If the polling password is set to “0000”, the unit does not check the password sent by other facsimile machines.

# Preparation for being polled

In order to let other units poll your unit, you must set the documents in the document feeder tray of your unit.

1

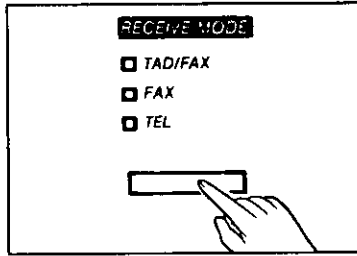

Set the unit in the TAD/FAX or FAX mode.

2

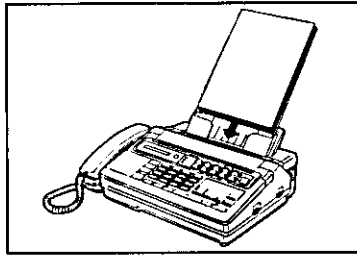

Insert the documents FACE DOWN.

3

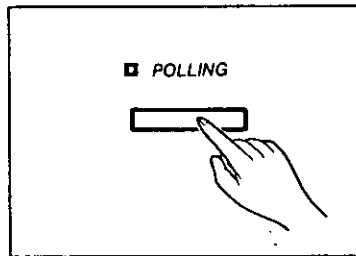

Press the POLLING button.

The POLLING indicator lights after flashing.

The unit is ready for being polled.

When the other unit polls your unit, transmission is carried out automatically.

## HELPFUL HINT

- If you want to cancel being polled before transmission, press the POLLING button, then remove the documents from the unit. The POLLING indicator will go out.

# Polling another unit

The following procedure lets you poll another station.  
Make sure that no documents have been fed into the unit.

1

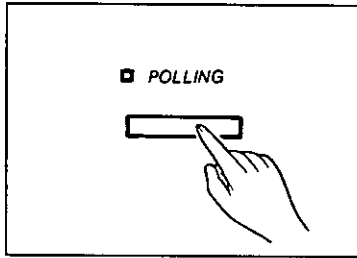

Press the POLLING button.

The POLLING indicator flashes.

2

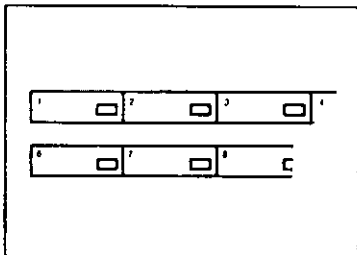

Enter the phone number you wish to poll while the POLLING indicator is flashing.

### Using one touch dialing:

Press the desired direct call station key.

The unit will dial and receive documents.

When reception ends, the POLLING indicator goes out.

OR

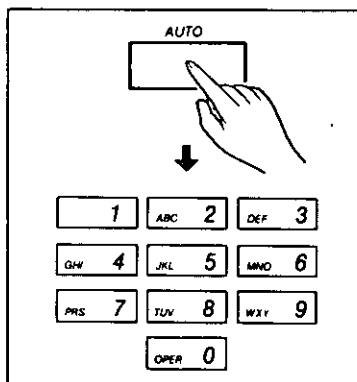

OR

### Using speed dialing:

Press the AUTO button, then press the desired station number ("00" through "49") using the dial keypad.

The unit will dial and receive documents.

When reception ends, the POLLING indicator goes out.

OR

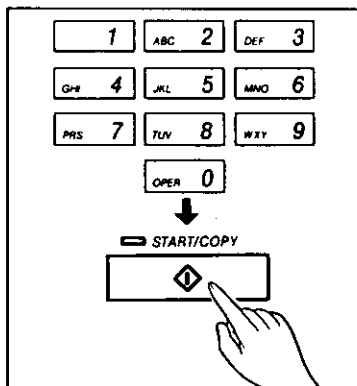

OR

### Using manual dialing:

Dial the desired phone number, then press the START/COPY button.

The unit will start receiving documents.

When reception ends, the POLLING indicator goes out.

### HELPFUL HINTS

- If the polled station is busy or there is no answer, the unit automatically redials up to 6 times within 10 minutes.
- If you want to cancel polling before reception, press the POLLING button again or press the STOP/CLEAR button. The POLLING indicator will go out.

# ●Network communication

The network communication function with network passcode can eliminate fax transmission to unauthorized parties, and help to prevent reception from an unauthorized station.

This feature is effective to prevent "Junk mail" faxes since only those units with the same passcode can transmit to your unit.

When the network communication function is used, the identical network passcode of 4 digits must be programmed on both sides of the line. The unit checks the passcode before transmitting or receiving a document.

The unit provides two types of passcode check modes. They are TX (transmission) passcode check mode and RX (receiving) passcode check mode.

## **TX Passcode Check:**

This function can be used when you wish to transmit a document only to authorized stations. If the passcode sent from the other Quasar compatible machines does not match with the one programmed in your unit, transmission does not take place. (See page 4-19 for TX passcode check setting.)

## **RX Passcode Check:**

This function can be used when you wish to receive a document only from authorized stations. If the passcode sent from the other Quasar compatible machines does not match with the one programmed in your unit, reception does not take place. (See page 4-20 for RX passcode check setting.)

This feature is effective only between Quasar compatible machines that have the same passcode.

## **HELPFUL HINT**

- The password for the polling function is not related to this network communication. They are independent functions.

# Programming the network passcode

To activate this feature, the identical network passcode must be preprogrammed both on your unit and the other compatible machine(s). Follow the steps below.

1

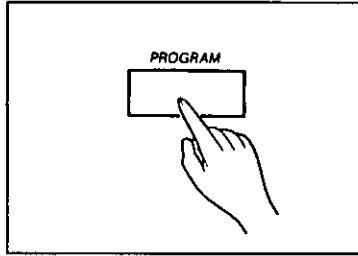

Press the PROGRAM button.

The PROGRAM indicator lights and the display shows "P-\_".

2

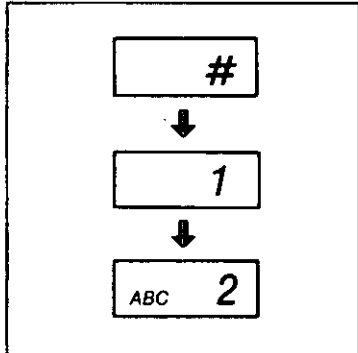

Press "#", then press "12" for NETWORK PASSCODE setting.

The display shows "P-F12 0000".

3

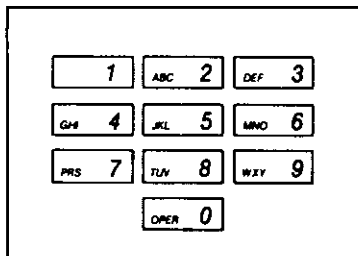

Enter the desired passcode of 4 digits using the dial keypad.

You can choose among numbers "0001" through "9999" as the network passcode.

To correct an error, press the STOP/CLEAR button then correct input.

4

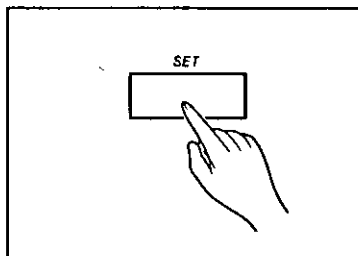

Press the SET button to store the programming in memory.

The display shows "P-\_".

5

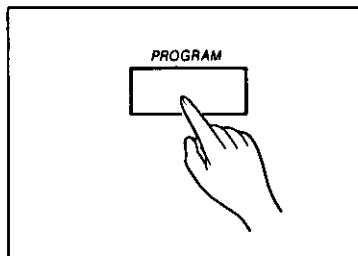

Press the PROGRAM button to end the operation.

The PROGRAM indicator goes out.

## HELPFUL HINT

- The network passcode is set to "0000" as the default.



# Turning the TX passcode check on

1

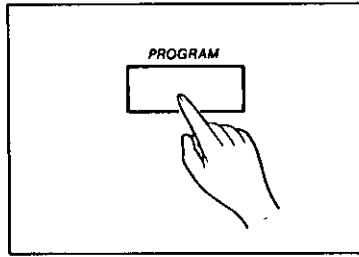

Press the PROGRAM button.

The PROGRAM indicator lights and the display shows "P-\_".

2

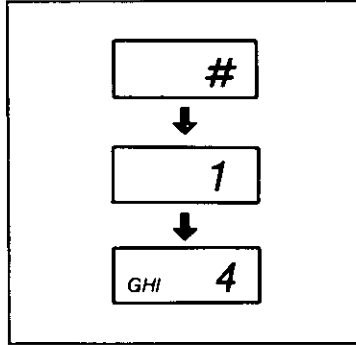

Press "#", then press "14" for TX PASSCODE CHECK setting.

The display shows "P-F14 2".

Setting selections are;

1: ON (activate this function)

2: OFF (deactivate this function)

3

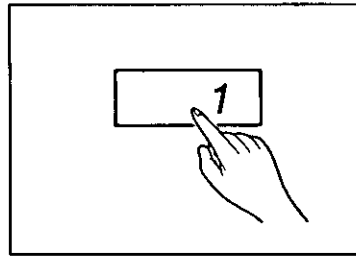

Press "1" to activate this function.

The display shows "P-F14 1".

4

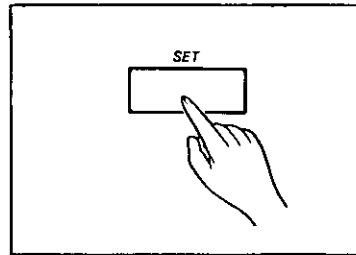

Press the SET button to store your selection in memory.

The display shows "P-\_".

5

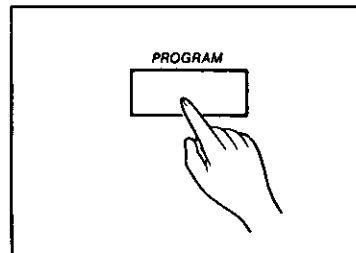

Press the PROGRAM button to end the operation.

The PROGRAM indicator goes out.

## HELPFUL HINT

•If the network passcode is set to "0000", the unit does not check the passcode.

# Turning the RX passcode check on

1

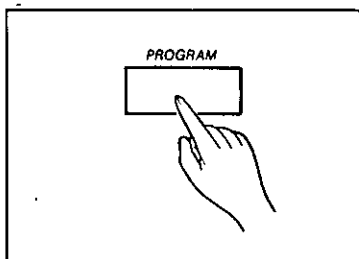

Press the PROGRAM button.

The PROGRAM indicator lights and the display shows "P-\_".

2

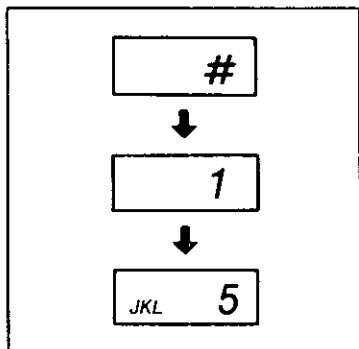

Press "#", then press "15" for RX PASSCODE CHECK setting.

The display shows "P-F15 2".

Setting selections are;

1: ON (activate this function)

2: OFF (deactivate this function)

3

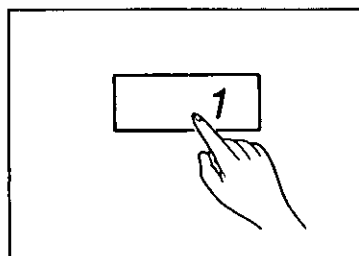

Press "1" to activate this function.

The display shows "P-F15 1".

4

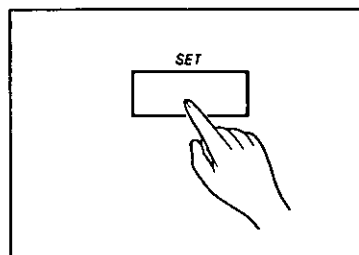

Press the SET button to store your selection in memory.

The display shows "P-\_".

5

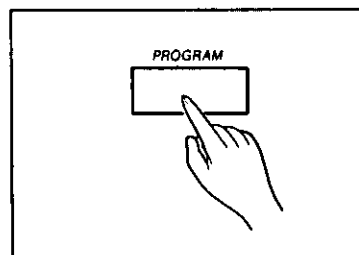

Press the PROGRAM button to end the operation.

The PROGRAM indicator goes out.

## HELPFUL HINT

- If the network passcode is set to "0000", the unit does not check the passcode.

# CHAPTER 5

## *Printing Reports and Lists*

<b>Activity report (JOURNAL report)</b> .....	5-2
Setting JOURNAL AUTO PRINT .....	5-3
Printing JOURNAL report.....	5-4
<b>Individual transmission report (TX REPORT)</b> .....	5-5
Setting TX REPORT .....	5-5
<b>List of stored phone numbers</b> .....	5-6
Printing the TELEPHONE NUMBER LIST .....	5-6
<b>ERROR CODE LIST</b> .....	5-7
<b>CHARACTER CODE LIST</b> .....	5-8

# ●Activity report (JOURNAL report)

You can obtain a record of the last 30 transactions (transmissions and receptions) automatically or manually. When the JOURNAL AUTO PRINT of the programming functions is set to "ON", the report will be printed automatically after every 30 transactions. After each 30 transactions, the report is cleared and the list begins again. It may also be printed on request.

**This function has been preset to ON as the default.**

These reports are useful for keeping records of telephone usage or verifying telephone long distance charges.

Print time: Hour:Minute AM/PM

Print date: Month/Date/Year

```
***** JOURNAL *****
*
*                               Jan. 21 1991 11:42AM
*
* NO.   OTHER FACSIMILE   MODE   PAGES   START TIME   USAGE TIME   RESULT
*-----
* 01    1234567           TX      03    Jan. 21 10:00AM   01'05       OK
* 02     G3              RX      03    Jan. 21 10:02AM   00'59       OK
* 03    9876543           RX      01    Jan. 21 10:05AM   00'44       OK
* 04    9876543           TX      02    Jan. 21 10:09AM   01'05       OK
* 05    4445555           TX      02    Jan. 21 10:13AM   01'16       OK
* 06    2223333           TX      01    Jan. 21 10:16AM   00'49       OK
* 07    SMITH             POL. RX 01    Jan. 21 10:19AM   00'51       OK
* 08    SMITH             TX      00    Jan. 21 10:22AM   00'00       NG(09)
* 09    Quasar            POL. TX 01    Jan. 21 10:27AM   00'44       OK
* 10    <S02>              TX      01    Jan. 21 10:31AM   01'32       OK
* 11    4445555           TX      01    Jan. 21 11:21AM   00'48       OK
* 12    <A00>              TX      01    Jan. 21 11:23AM   02'09       OK
* 13     G3              RX      02    Jan. 21 11:27AM   00'49       OK
* 14    Quasar            RX      01    Jan. 21 11:32AM   01'11       OK
* 15    <A02>              TX      01    Jan. 21 11:36AM   00'47       OK
* 16    <S01>              TX      01    Jan. 21 11:37AM   00'27       OK
* 17    9991111           TX      00    Jan. 21 11:42AM   00'29       NG(02)
*****
```

Communication number (up to 30)

Dial number (Example)

Transaction mode:  
TX ... Transmission  
RX ... Reception  
POL. TX ... Being Polled  
POL. RX ... Polling

Number of pages received or transmitted successfully

Communication start time

Length of communication:  
Minutes' Seconds

Communication result:  
OK ... Successful communication  
Numeral Following NG ... Error code

# Setting JOURNAL AUTO PRINT

1

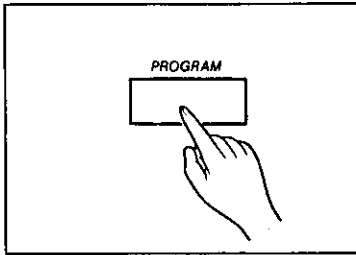

Press the PROGRAM button.

The PROGRAM indicator lights and the display shows "P-\_".

2

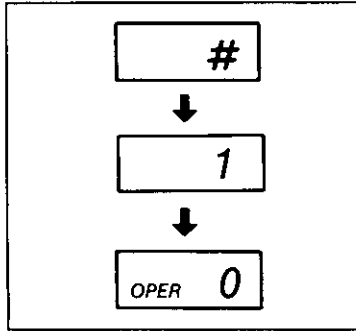

Press "#", then press "10" for JOURNAL AUTO PRINT setting.

The display shows "P-F10 1"

Setting selections are;

1: ON (Prints a report every 30 transactions automatically.)

2: OFF

3

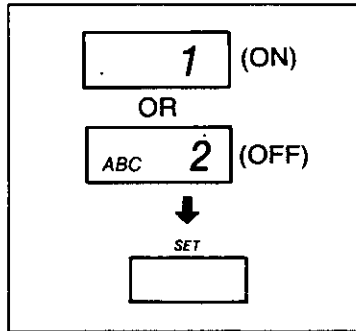

Press "1" or "2", then press the SET button to store your selection in memory

The display shows "P-\_".

4

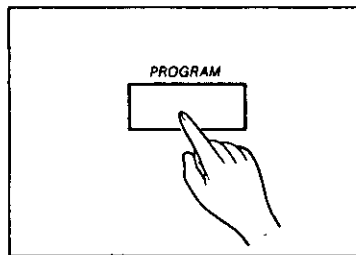

Press the PROGRAM button to end the operation.

The PROGRAM indicator goes out.

# Printing JOURNAL report

You can print a report of the current JOURNAL upon request. This will not clear the report which will continue until 30 transactions are completed.

1

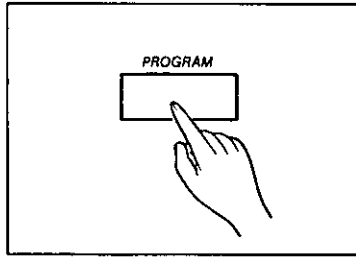

Press the PROGRAM button.

The PROGRAM indicator lights and the display shows "P-\_".

2

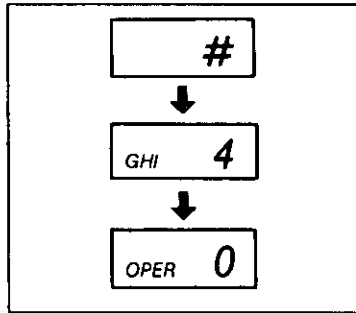

Press "#", then press "40" for PRINT JOURNAL setting.

The display shows "P-F40".

3

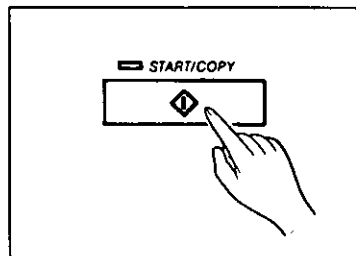

Press the START/COPY button to obtain a report.

The unit will start printing.  
If there have been no transactions, no JOURNAL is printed.

4

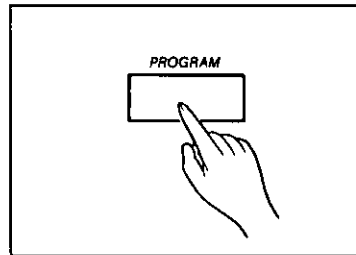

Press the PROGRAM button to end the operation.

The PROGRAM indicator goes out.



# List of stored phone numbers

You can print a list of the numbers programmed for one touch dialing and speed dialing. Use this function to confirm that you have correctly stored phone numbers.

```
***** TELEPHONE NUMBER LIST *****
*
*                                     Jan. 21 1991  3:01PM
*
*           << STATION KEY LIST >>
*-----
*   PHONE NUMBER           PHONE NUMBER
* 01 T123-4567             06 T0987-654-3210
* 02 T789-1234             07 R( )-012-( )
* 03 P333-3333             08
* 04                       09
* 05                       10
*
*
*           << AUTO KEY LIST >>
*-----
*   PHONE NUMBER           PHONE NUMBER
* 00 T233-5555             25 R111-222-3333
* 01 R456-P753-7568        26 R123-F465-7890
* 02 T( )                  27 R( )
* 03                       28
* 04                       29
* 05 T748-7539             30
* 06                       31
* 07                       32
* 08                       33
* 09                       34
* 10                       35
* 11                       36
*                          37
*
*                               SECRET NUMBER
*
*-----
```

### Codes in each phone number

T: Shows that you have entered the telephone number in the TONE dialing mode.

R: Shows that you have entered the telephone number in the PULSE (rotary) dialing mode.

P: Shows that you have entered PAUSE.

F: Shows that you have entered FLASH.

## Printing the TELEPHONE NUMBER LIST

1

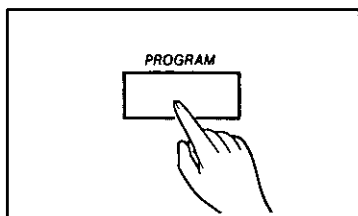

Press the PROGRAM button.

The PROGRAM indicator lights and the display shows "P-\_".

2

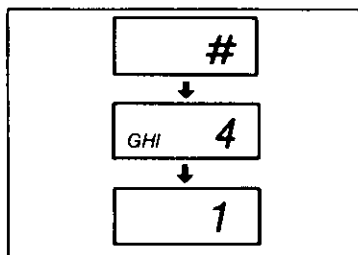

Press the "#", then press "4" for PRINT TEL LIST setting.

The display shows "P-F41".

3

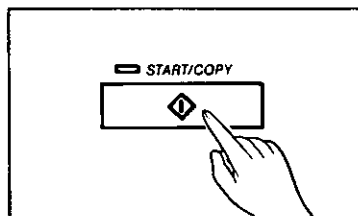

Press the START/COPY button.

The unit starts printing.

4

Press the PROGRAM button to end the operation.

The PROGRAM indicator goes out.



# ●ERROR CODE LIST

***** ERROR CODE LIST *****		
Code	Contents	Countermeasure
01	: Power supply overheating.	Allow the unit to cool.
02	: Interrupted transmission.	Retry or check parameters.
03	: Document jammed or not fed into the unit properly.	Check document path.
04	: Transmission or reception error.	Retry the operation.
05	: Printing head overheating.	Allow the unit to cool.
06	: The unit is out of recording paper.	Check recording paper.
07	: The cover is open.	Check cover latch.
08	: Recording paper jammed.	Re-install recording paper.
09	: Password communication failed.	Confirm that your password corresponds to that of the other unit.
20	: Memory (phone numbers, parameters, etc.) has been erased. Reprogram.	Check your messages.

To obtain the ERROR CODE LIST;

1

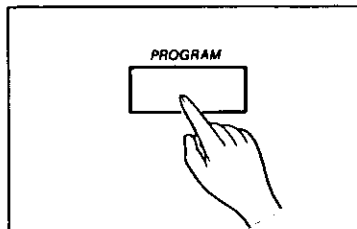

Press the PROGRAM button.

The PROGRAM indicator lights and the display shows "P\_".

2

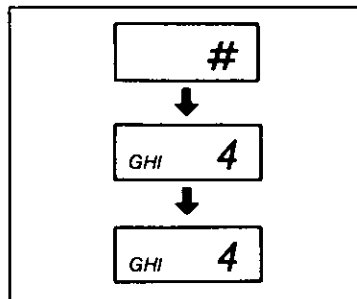

Press "#", then press "44" for PRINT ERROR CODE LIST setting.

The display shows "P-F44".

3

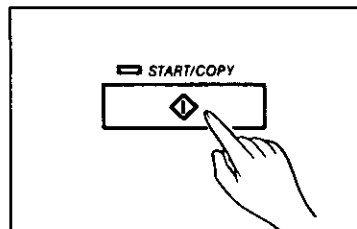

Press the START/COPY button.

The unit will start printing.

4

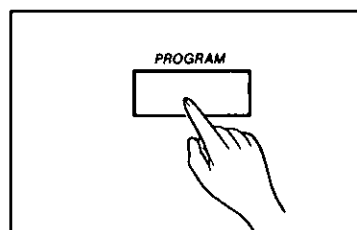

Press the PROGRAM button to end the operation.

The PROGRAM indicator goes out.

# ● CHARACTER CODE LIST

This list is useful as a code reference when programming your logo heading.

```

***** CHARACTER CODE LIST *****
*
* AC: 00 > : 10 0 : 20 A : 30 K : 40 U : 50 a : 60 k : 70 u : 80 _ : 90 *
* SP: 01 * : 11 1 : 21 B : 31 L : 41 V : 51 b : 61 l : 71 v : 81 ' : 91 *
* ! : 02 + : 12 2 : 22 C : 32 M : 42 W : 52 c : 62 m : 72 w : 82 < : 92 *
* " : 03 , : 13 3 : 23 D : 33 N : 43 X : 53 d : 63 n : 73 x : 83 | : 93 *
* # : 04 - : 14 4 : 24 E : 34 O : 44 Y : 54 e : 64 o : 74 y : 84 > : 94 *
* $ : 05 . : 15 5 : 25 F : 35 P : 45 Z : 55 f : 65 p : 75 z : 85 + : 95 *
* % : 06 / : 16 6 : 26 G : 36 0 : 46 = : 56 g : 66 q : 76 [ : 86 BS: 96 *
* & : 07 : : 17 7 : 27 H : 37 R : 47 > : 57 h : 67 r : 77 ¥ : 87 : 97 *
* ' : 08 ; : 18 8 : 28 I : 38 S : 48 ? : 58 i : 68 s : 78 ] : 88 : 98 *
* ( : 09 < : 19 9 : 29 J : 39 T : 49 @ : 59 j : 69 t : 79 ^ : 89 : 99 *
*
*
* AC : "All Clear", SP : "Space", BS : "Back Space"
*
*****

```

To obtain the CHARACTER CODE LIST;

1

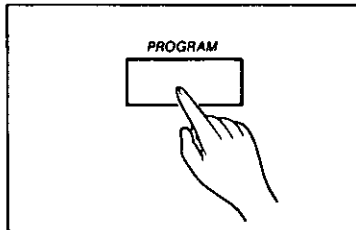

Press the PROGRAM button.

The PROGRAM indicator lights and the display shows "P-\_".

2

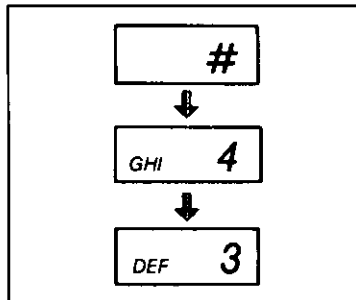

Press "#", then press "43" for PRINT CHARACTER CODE setting.

The display shows "P-F43".

3

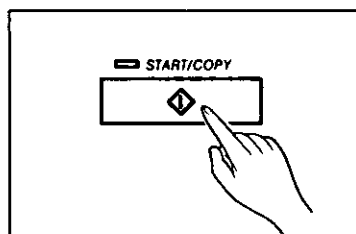

Press the START/COPY button.

The unit will start printing.

4

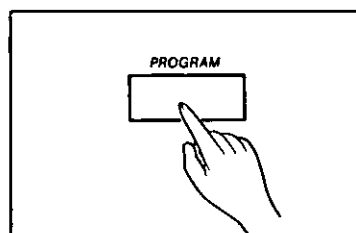

Press the PROGRAM button to end the operation.

The PROGRAM indicator goes out.

# Chapter 6

## System Programming Functions

<b>User programmable functions</b> .....	6-2
FAX LOGO HEADING .....	6-2
FAX TX SPEED .....	6-2
FAX RX SPEED .....	6-3
TONE DETECT .....	6-3
RECORDING TIME .....	6-4
CPC (Calling Party Control) MODE .....	6-4
TAD/FAX RING COUNT .....	6-5
FAX RING COUNT .....	6-5
<b>Resetting user programmable functions</b> .....	6-6
<b>Printing the SYSTEM SETUP LIST</b> .....	6-7
<b>Service functions</b> .....	6-8
Printing the SERVICE DATA LIST .....	6-8
programming the service functions .....	6-8

# ●User programmable functions

## FAX LOGO HEADING

ON: Your logo and telephone number are printed on the top of faxes sent by your unit. (Default)  
OFF: Your logo and telephone number are not printed.

### Operation

- 1 Press the PROGRAM button.  
The PROGRAM indicator lights and the display shows "P-\_".
- 2 Press "#", then press "05" for FAX LOGO HEADING setting.  
The display shows "P-F05 1".
- 3 Press "1" or "2".  
(1=ON, 2=OFF)
- 4 Press the SET button to store your selection in memory.
- 5 Press the PROGRAM button to end the operation.  
The PROGRAM indicator goes out.

## FAX TX SPEED

The unit automatically selects the optimum transmitting speed depending on the line condition and the type of the other facsimile unit. If you frequently experience problems such as transmission errors caused by poor line condition, set to "4800 BPS".

9600 BPS: Maximum speed of 9600 bits per second. (Default)

4800 BPS: Maximum speed of 4800 bits per second.

### Operation

- 1 Press the PROGRAM button.  
The PROGRAM indicator lights and the display shows "P-\_".
- 2 Press "#", then press "17" for FAX TX SPEED setting.  
The display shows "P-F17 1".
- 3 Press "1" or "2".  
(1=9600 BPS, 2=4800 BPS)
- 4 Press the SET button to store your selection in memory.
- 5 Press the PROGRAM button to end the operation.  
The PROGRAM indicator goes out.

# FAX RX SPEED

The unit automatically selects the optimum receiving speed depending on the line condition and the type of the other facsimile unit. If you frequently experience problems such as reception errors caused by poor line condition, set to "4800 BPS".

9600 BPS: Maximum speed of 9600 bits per second. (Default)

4800 BPS: Maximum speed of 4800 bits per second.

## Operation

- 1 Press the PROGRAM button.  
The PROGRAM indicator lights and the display shows "P-\_".
- 2 Press "#", then press "18" for FAX RX SPEED setting.  
The display shows "P-F18 1".
- 3 Press "1" or "2".  
(1=9600 BPS, 2=4800 BPS)
- 4 Press the SET button to store your selection in memory.
- 5 Press the PROGRAM button to end the operation.  
The PROGRAM indicator goes out.

# TONE DETECT

The unit automatically disconnects the line when it detects a busy tone after dialing in on-hook dialing mode.

OFF: The unit does not detect a busy tone. (Default)

ON: The unit detects a busy tone.

## Operation

- 1 Press the PROGRAM button.  
The PROGRAM indicator lights and the display shows "P-\_".
- 2 Press "#", then press "20" for TONE DETECT setting.  
The display shows "P-F20 2".
- 3 Press "1" or "2".  
(1=ON, 2=OFF)
- 4 Press the SET button to store your selection in memory.
- 5 Press the PROGRAM button to end the operation.  
The PROGRAM indicator goes out.

# RECORDING TIME

The recording time for incoming messages can be set to VOX (unlimited) or 1 MIN (1 minute).

VOX: The unit records an ICM as long as a caller speaks. (Default)

1 MIN: The unit records an ICM up to 1 minute per message.

## Operation

- 1 Press the PROGRAM button.  
The PROGRAM indicator lights and the display shows "P-".
- 2 Press "#", then press "30" for RECORDING TIME setting.  
The display shows "P-F30 1".
- 3 Press "1" or "2".  
(1=VOX, 2=1 MIN)
- 4 Press the SET button to store your selection in memory.
- 5 Press the PROGRAM button to end the operation.  
The PROGRAM indicator goes out.

# CPC (Calling Party Control) MODE

Select the CPC mode "A" or "B" depending on your line condition.

A: Set to this mode if your line does not have special telephone services. (Default)

B: Set to this mode if your line has special telephone services such as call waiting and call forwarding. If some incoming messages are cut off in mode "A", set the mode to "B".

## Operation

- 1 Press the PROGRAM button.  
The PROGRAM indicator lights and the display shows "P-".
- 2 Press the "#", then press "31" for CPC MODE setting.  
The display shows "P-F31 1".
- 3 Press "1" or "2".  
(1=A, 2=B)
- 4 Press the SET button to store your selection in memory.
- 5 Press the PROGRAM button to end the operation.  
The PROGRAM indicator goes out.

# TAD/FAX RING COUNT

This function is available only in the TAD/FAX mode when receiving a call.

If you find there is difficulty in receiving from machines that have an automatic transmission feature, set TAD/FAX RING COUNT number to "1" (once).

- 0: Toll Saver (See page 4-4.)
- 1: The unit answers on the 1st ring. (Default)
- 2: The unit answers on the 2nd ring.
- 3: The unit answers on the 3rd ring.
- 4: The unit answers on the 4th ring.

## Operation

- 1 Press the PROGRAM button.  
The PROGRAM indicator lights and the display shows "P-\_".
- 2 Press the "#", then press "32" for TAD/FAX RING COUNT setting.  
The display shows "P-F32 1".
- 3 Press "0", "1", "2", "3" or "4".  
(0=Toll Saver, 1=once, 2=twice, 3=three times, 4=four times)
- 4 Press the SET button to store your selection in memory.
- 5 Press the PROGRAM button to end the operation.  
The PROGRAM indicator goes out.

# FAX RING COUNT

This function is available only in the FAX mode when receiving a document.

If you find there is difficulty in receiving from machines that have an automatic transmission feature, set FAX RING COUNT number to "1" (once).

- 1: The unit answers on the 1st ring. (Default)
- 2: The unit answers on the 2nd ring.
- 3: The unit answers on the 3rd ring.
- 4: The unit answers on the 4th ring.

## Operation

- 1 Press the PROGRAM button.  
The PROGRAM indicator lights and the display shows "P-\_".
- 2 Press the "#", then press "33" for FAX RING COUNT setting.  
The display shows "P-F33 1".
- 3 Press "1", "2", "3" or "4".  
(1=once, 2=twice, 3=three times, 4=four times)
- 4 Press the SET button to store your selection in memory.
- 5 Press the PROGRAM button to end the operation.  
The PROGRAM indicator goes out.

# ●Resetting user programmable functions

This operation enables you to return the user programmable functions of 05 through 34 to their initial default settings. The function number 01 through 04 will not be erased.

## Operation

- 1 Press the PROGRAM button.  
The PROGRAM indicator lights and the display shows "P-".
- 2 Press the "#", then press "50" for RESET USER PROGRAMMABLE FUNCTIONS setting.  
The display shows "P-F50".
- 3 Press the START/COPY button.  
The following message is printed.

```
USER PROGRAMMABLE FUNCTIONS RESET OK?   YES: PRESS "START/COPY"  
                                           NO : PRESS "STOP/CLEAR"
```

- 4 Press the START/COPY button to return to initial settings.  
The following message will be printed.

```
USER PROGRAMMABLE FUNCTIONS RESET COMPLETED!
```

OR

Press the STOP/CLEAR button to cancel.

- 5 Press the PROGRAM button to end the operation.  
The PROGRAM indicator goes out.



# ●Printing the SYSTEM SETUP LIST

The SYSTEM SETUP LIST provides you with an easy guide for quick programming.  
It is also useful when you confirm the current settings of the programming functions.

```

***** SYSTEM SET UP LIST *****
*
* #01 SET DATE = Jan.01 1990 12:00AM [+:AM/PM Switch] *
* #02 YOUR LOGO = *
* #04 YOUR TELEPHONE NUMBER = *
* #05 FAX LOGO HEADING = ON ( 1 = ON 2 = OFF ) *
* #06 REMOTE TAD ID = 111 *
* #08 PRIVACY RING ID = 333 *
* #10 JOURNAL AUTO PRINT = ON ( 1 = ON 2 = OFF ) *
* #11 PRINT TX REPORT = OFF ( 1 = ON 2 = ERROR 3 = OFF ) *
* #12 NETWORK PASSCODE = 0000 *
* #14 TX PASSCODE CHECK = OFF ( 1 = ON 2 = OFF ) *
* #15 RX PASSCODE CHECK = OFF ( 1 = ON 2 = OFF ) *
* #16 POLLING PASSWORD = 0000 *
* #17 FAX TX SPEED = 9600BPS ( 1 = 9600BPS 2 = 4800BPS ) *
* #18 FAX RX SPEED = 9600BPS ( 1 = 9600BPS 2 = 4800BPS ) *
* #20 TONE DETECT = OFF ( 1 = ON 2 = OFF ) *
* #30 RECODING TIME = VOX ( 1 = VOX 2 = 1MIN ) *
* #31 CPC MODE = A ( 1 = A 2 = B ) *
* #32 TAD/FAX RING COUNT = 1 ( 0...4 0:TOLL SAVER ) *
* #33 FAX RING COUNT = 1 ( 1...4 ) *
* #34 AUTO RECEIVE TIMER = OFF ( 1 = ON 2 = OFF ) *
* ON TIME = 12:00AM *
* MODE = TAD/FAX ( 1:TAD/FAX 2:FAX ) *
* OFF TIME = 12:00AM *
* MODE = TELEPHONE ( 1:TAD/FAX 2:FAX 3:TELEPHONE ) *
*
* #40 PRINT JOURNAL *
* #41 PRINT TEL LIST *
* #42 PRINTER TEST *
* #43 PRINT CHARACTER CODE *
* #44 PRINT ERROR CODE LIST *
* #50 RESET USER PROGRAMMABLE FUNCTIONS ( #05 TO #34 ) *
* #9000* ( SERVICE DATA SET UP ) *
*
* --<< HOW TO SET UP >>-- *
* 1. PRESS "PROGRAM" *
* 2. PRESS "#" THEN "CODE NO." *
* 3. ENTER DESIRED VALUE *
* 4. PRESS "SET" TO STORE YOUR SELECTION *
* OR PRESS "START/COPY" *
* FOR #40,#41,#42,#43,#44,#50 *
* 5. PRESS "PROGRAM" AGAIN TO END SET UP *
*
* --<< HOW TO PROGRAM PHONE NO. >>-- *
* 1. CHECK "DIALING MODE" SELECTOR *
* 2. PRESS "PROGRAM" *
* 3. PRESS "DIRECT CALL" STATION *
* OR PRESS "AUTO" AND "00-49" *
* 4. ENTER PHONE NO. *
* 5. PRESS "SET" TO STORE PHONE NO. *
* TO STORE IN SUCCESSION, *
* REPEAT STEP 3 TO 5 *
* 6. PRESS "PROGRAM" TO END SET UP *
*
*****

```

To obtain the SYSTEM SETUP LIST;

1

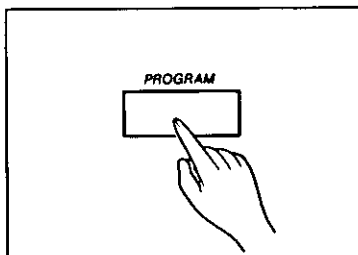

Press the PROGRAM button.

The PROGRAM indicator lights.

2

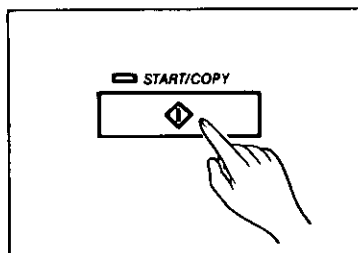

Press the START/COPY button.

The unit starts printing the SYSTEM SETUP LIST.  
When finished, the PROGRAM indicator light goes out.

# •Service functions

The following service functions can be changed as the need arises. For further details, consult with your service center.

```
***** SERVICE DATA LIST *****
*
*      01 PAUSE TIME      = 500ms ( 000...600 *100ms )      *
*      02 FLASH TIME     = 700ms ( 01... 99 *10ms )      *
*      03 DIAL SPEED     = 10pps ( 1 = 10pps 2 = 20pps )  *
*      10 VOX TIME       = 6sec ( 1 = 6sec 2 = 4sec )    *
*      20 CED FREQ.      = 2100Hz ( 1 = 2100Hz 2 = 1100Hz ) *
*      21 INTL MODE      = ON ( 1 = ON 2 = OFF )        *
*      22 AUTO STANDBY/  = ON ( 1 = ON 2 = OFF )        *
*      23 RX EQL.        = 1.8km ( 1 = 0.0km 2 = 1.8km 3 = 3.6km 4 = 7.2km ) *
*      24 TX EQL.        = 1.8km ( 1 = 0.0km 2 = 1.8km 3 = 3.6km 4 = 7.2km ) *
*
*      << SPECIAL SERVICE SETTINGS >>
*
*      52 53 59 60 63 70 71 72 73 80 82 83 84 86 87 90 91 92 93 94 95 96 97 *
*      2 3 1 1 03 1 14 030 15 1 1 17 1 1 1 05 045 2 008 1 100 -10 5 *
*
*****
```

## Printing the SERVICE DATA LIST

You can obtain a list of service functions (SERVICE DATA LIST).

- 1 Press the PROGRAM button.  
The PROGRAM indicator lights and the display shows "P-".
- 2 Press "#", "9", "0", "0", "0" and "\*".  
The PROGRAM indicator flashes and the display shows "P-F".
- 3 Press the START/COPY button to start printing.
- 4 Press the PROGRAM button to end the operation.  
The PROGRAM indicator goes out.

## Programming the service functions

- 1 Press the PROGRAM button.  
The PROGRAM indicator lights and the display shows "P-".
- 2 Press "#", "9", "0", "0", "0" and "\*".  
The PROGRAM indicator flashes and the display shows "P-F".
- 3 Press the desired code number (01 through 24).
- 4 Press the desired value, then press the SET button to store your selection in memory.
- 5 Press the PROGRAM button to end the operation.  
The PROGRAM indicator goes out.

# CHAPTER 7

## *Troubleshooting and Maintenance*

<b>Error code</b> .....	7-2
<b>Troubleshooting guide</b> .....	7-3
The ALARM indicator.....	7-3
Facsimile.....	7-3
Answering Device & Telephone .....	7-4
Printer test .....	7-5
Paper jams.....	7-5
<b>Maintenance</b> .....	7-6
Cassette deck.....	7-6
Facsimile machine .....	7-7
<b>Specifications</b> .....	7-8

# ●Error code

The error code appears on the display when any troubles occur.

<example>

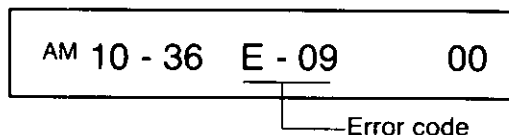

The error code also corresponds to the numeral following "NG" on the JOURNAL and the TX REPORT.

ERROR CODE	CAUSE & REMEDY
01	Power supply overheating. Allow the unit to cool.
02	Interrupted transmission. Retry or check parameters.
03	Document jammed or not fed into the unit properly. Check document path. If a document is jammed, open the cover, then remove the document.
04	Transmission or reception error. Retry the operation.
05	Printing head overheating. Allow the unit to cool.
06	The unit is out of recording paper. Check recording paper.
07	The cover is open. Check cover latch.
08	Recording paper jammed. Re-install recording paper.
09	Network communication failed. Confirm that your passcode corresponds to that of the other unit.
20	Memory check error. Memory (phone numbers, parameters, etc.) has been erased. Reprogram.
21	Power failed. Call counter="- -" Check your messages.
22	Timer IC error. Service required.
30	OGM is not recorded. Record your OGM.
31	Microphone error. Service required.
32	ICM recording tape is broken or not installed. Install a new tape, and record your OGM.

# ●Troubleshooting guide

## The ALARM indicator

PROBLEM	CAUSE & REMEDY
The indicator flashes after transmission.	●A transmission error has occurred. Try again.
The indicator lights.	●Confirm that the covers of the unit are closed firmly. ●Your OGM is not recorded. See page 2-6.
The indicator lights during transmission.	●A document more than 600 mm (23 <sup>5</sup> / <sub>8</sub> " ) is being transmitted. ●A document is jamming. Remove it. ●Connect the unit to a line that does not have special telephone service such as call waiting.
The indicator lights during copying or receiving.	●The recording paper is jamming. Remove it.

## Facsimile

PROBLEM	CAUSE & REMEDY
I cannot receive documents automatically.	●Make sure that recording paper is installed properly. ●Make sure the RECEIVE MODE of the unit is set to TAD/FAX or FAX mode and not to TEL mode. ●Shorten your OGM.
Recording image is faint and I cannot read it well.	●The sender transmitted a faint document. Request him to transmit a more clear document (e.g. copied one) again.
The other party complains that the letters on the document are distorted.	●If your line has special telephone service such as call waiting, it may have been activated by another telephone call. Connect the unit to a line that does not have such service. ●Be sure another telephone is not connected to the same line as your unit.
The START/COPY indicator flashes for about 40 seconds after the unit receives a call automatically, but nothing is recorded.	●The caller hangs up during or immediately after playing back your OGM. This may occur if the disconnect signal is not transmitted from the central office.
When I receive or copy a document that has a dark background or contains photographs, the unit produces a high pitched noise.	●This is quite normal.

<b>The unit does not operate properly.</b>	<ul style="list-style-type: none"> <li>•Turn the POWER switch off, then turn it on again.</li> </ul>
<b>Problems when receiving international facsimiles.</b>	<ul style="list-style-type: none"> <li>•Shorten your OGM to 10 seconds or less.</li> <li>•FAX RX SPEED may need to be set to 4800 bps. See page 6-3.</li> </ul>

## Answering Device & Telephone

<b>PROBLEM</b>	<b>CAUSE &amp; REMEDY</b>
<b>The unit does not work when any button is pressed.</b>	<ul style="list-style-type: none"> <li>•Turn the POWER switch off, then turn it on again.</li> </ul>
<b>The unit has been set to the TAD/FAX mode, but no voice-messages have been recorded.</b>	<ul style="list-style-type: none"> <li>•The tape is not installed properly or is broken (cut, worn out or twisted). Install the tape or replace it with a new one.</li> </ul>
<b>When the tape is played, the sound level is low or nothing can be heard.</b>	<ul style="list-style-type: none"> <li>•Raise the sound level using the VOLUME control.</li> <li>•Clean the head of the cassette deck compartment. See page 7-6.</li> </ul>
<b>I have played back all the recorded messages and I want to record the next call after the last message.</b>	<ul style="list-style-type: none"> <li>•Leave the unit as it is after hearing the messages.</li> </ul>
<b>I cannot retrieve recorded messages from a remote phone.</b>	<ul style="list-style-type: none"> <li>•Make sure that you use your REMOTE TAD ID number correctly.</li> <li>•When you press your REMOTE TAD ID number, press the buttons firmly.</li> </ul>
<b>Some voice-messages have not been fully recorded.</b>	<ul style="list-style-type: none"> <li>•Set the calling party control (CPC) to "B". See page 6-4.</li> </ul>
<b>When a caller hangs up after leaving a message, the tape does not stop.</b>	<ul style="list-style-type: none"> <li>•VOX TIME should be set to 4 seconds. See page 6-8.</li> </ul>
<b>The unit does not ring.</b>	<ul style="list-style-type: none"> <li>•Set the RINGER volume selector to the HIGH or LOW position.</li> </ul>

## Printer test

You can check the print quality of your unit by printing the test pattern.  
If the test pattern has any blurred points or lines or a dirty pattern, consult with your service center.

To obtain the test pattern, follow the steps below.

- 1 Press the PROGRAM button.  
The PROGRAM indicator lights and the display shows "P-".
- 2 Press "#", then press "42" for PRINTER TEST setting.  
The display shows "P-F42".
- 3 Press the START/COPY button.  
The unit prints the pattern as shown in Figure 1.
- 4 Press the PROGRAM button to end the operation.  
The PROGRAM indicator goes out.

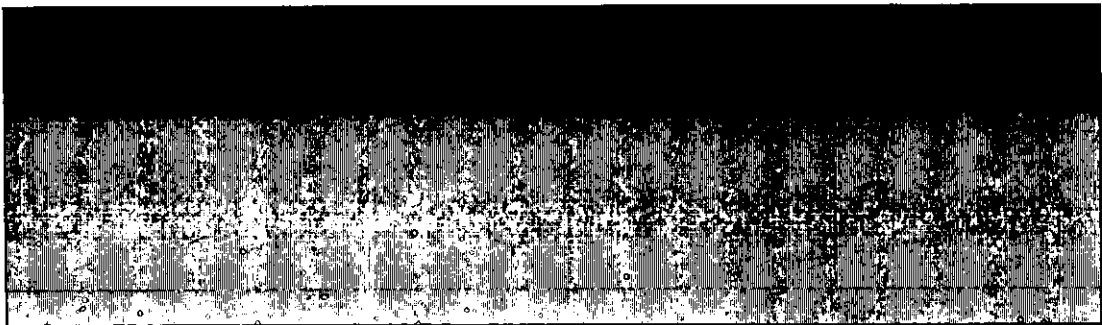

Figure 1

## Paper jams

**Document jams:** Open the cover by pressing the BACK LID OPEN lever and clear the document that is causing problem.

**Recording paper jams:** Open the cover by pressing the FRONT LID OPEN lever and remove the recording paper and re-install it properly. (See Recording paper installation on page 1-6.)

# ●Maintenance

Be sure that the AC plug is disconnected from the outlet before performing any maintenance.

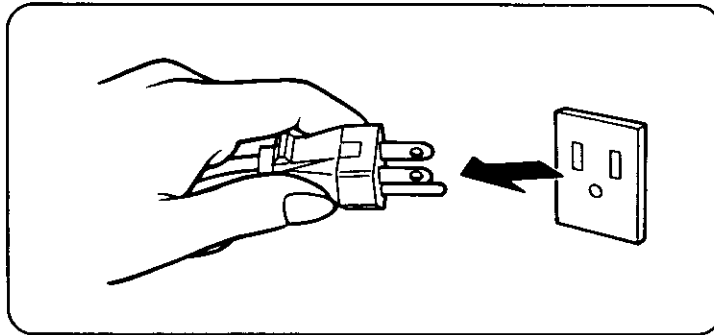

## Cassette deck

Since the head and capstan assemblies are in contact with the tape, dirt and residue from the tape may easily adhere to these parts, causing distortion. Clean these parts periodically in the manner described below for the best sound quality.

Clean the head surfaces, pinch roller and capstan with a cotton swab.

If these surfaces are extremely dirty, wipe them with a cotton swab dampened with alcohol, then wipe them with a dry soft cloth.

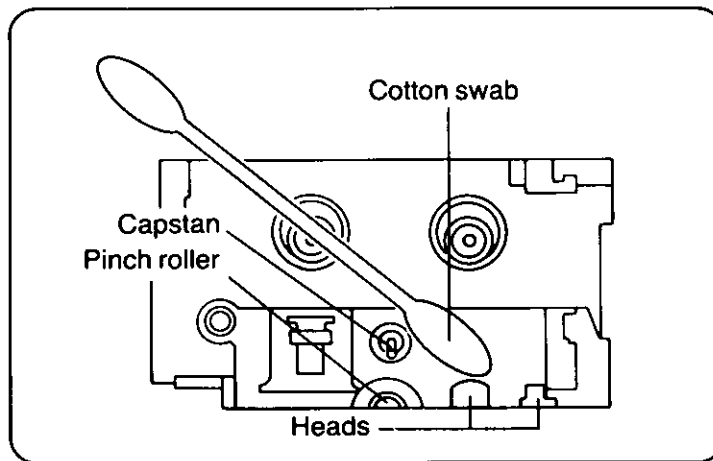

**Note:**

- Do not bring magnetic or metal objects, such as a screwdriver, near the head assembly, as such objects could magnetize the heads.
- Do not oil any part of the unit.



# Facsimile machine

If a streak or a dirty pattern appears on a copied, transmitted or received document;

1. Clean the glass with a dry soft cloth.
2. Clean the paper rollers with a damp cloth then dry thoroughly to prevent the paper from jamming.

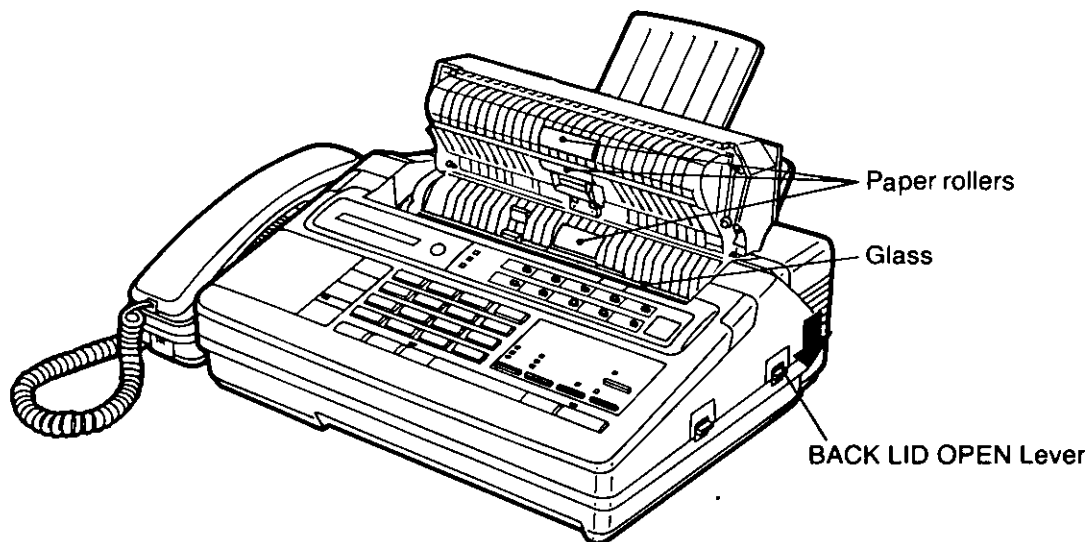

If you cannot get a clear copy after performing the above steps 1 and 2, clean the thermal head with a cloth moistened with denatured alcohol (alcohol without water), then dry thoroughly. To prevent malfunction due to static electricity, do not use a dry cloth and do not touch the thermal head with your finger directly.

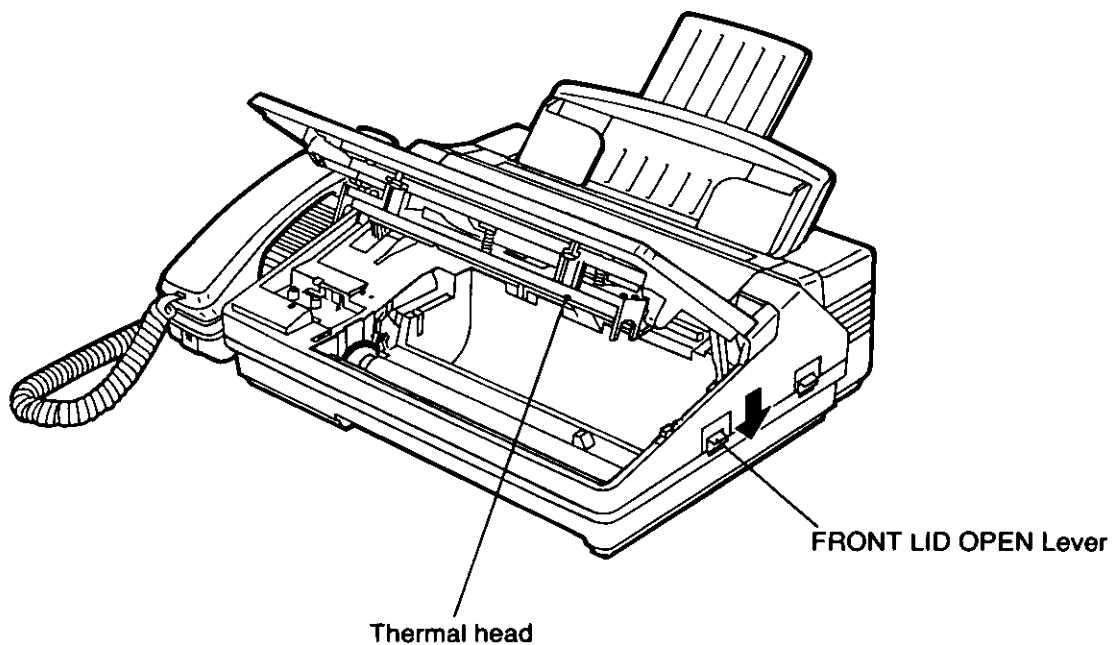

# ● Specifications

<b>Type:</b>	Desktop
<b>Applicable Lines:</b>	Public Switched Telephone Network
<b>Compatibility:</b>	CCITT G3
<b>Document Size:</b>	Max. 216 mm (8½") in width, Max. 600 mm (23⅝") in length
<b>Effective Scanning Width:</b>	Max. 208 mm (8⅜")
<b>Printing Paper Size:</b>	216 mm (letter) × 30 m roll (8½" × 98' roll)
<b>Effective Printing Width:</b>	208 mm (8⅜")
<b>Transmission Time*:</b>	Approx. 30 sec/page (G3 Normal mode) Approx. 17 sec/page (Original mode)
<b>Scanning Density:</b>	Horizontal 8 pels/mm (203 pels/inch) Vertical 3.85 lines/mm (98 lines/inch) Standard 7.7 lines/mm (196 lines/inch) Fine/Halftone 15.4 lines/mm (392 lines/inch) Superfine
<b>Scanner Type:</b>	CCD image sensor
<b>Printer Type:</b>	Thermal printing
<b>Data Compression System:</b>	Modified Huffman (MH)
<b>Modem Speed:</b>	9600/7200/4800/2400 bps; Automatic Fallback
<b>Automatic Document Feeder:</b>	Max. 10 sheets
<b>Temperature Range:</b>	5°~35°C (41°~95°F)
<b>Humidity Range:</b>	45%~85%
<b>Dimensions (H×W×D):</b>	125×429×312 mm (4⅘×16⅞×12⅘")
<b>Weight:</b>	5.5 kg (12.12 lbs)
<b>Power Consumption:</b>	Approx. 65 W
<b>Power Supply:</b>	AC 120 V, 60 Hz

\*Transmission Time: Transmission times apply to text data using CCITT No. 1 test chart, between same machine models at maximum modem speed.  
Transmission times vary in actual usage.

# SPEED DIALER LIST

CODE	NAME	CODE	NAME
00		25	
01		26	
02		27	
03		28	
04		29	
05		30	
06		31	
07		32	
08		33	
09		34	
10		35	
11		36	
12		37	
13		38	
14		39	
15		40	
16		41	
17		42	
18		43	
19		44	
20		45	
21		46	
22		47	
23		48	
24		49	

**Transmitting a document using the speed dialer:**

Insert the documents FACE DOWN, then press the AUTO button and the code number ("00" through "49").

# SPEED DIALER LIST

CODE	NAME	CODE	NAME
00		25	
01		26	
02		27	
03		28	
04		29	
05		30	
06		31	
07		32	
08		33	
09		34	
10		35	
11		36	
12		37	
13		38	
14		39	
15		40	
16		41	
17		42	
18		43	
19		44	
20		45	
21		46	
22		47	
23		48	
24		49	

**Transmitting a document using the speed dialer:**

Insert the documents FACE DOWN, then press the AUTO button and the code number ("00" through "49").

### QUICK REFERENCE CARD

#### FOR TONE REMOTE CONTROL

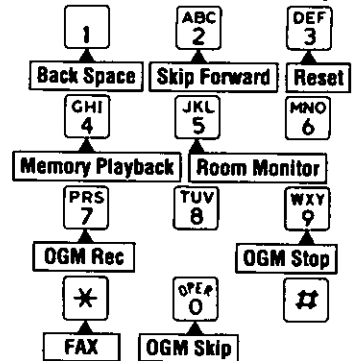

- To set the TAD/FAX mode, call your unit and wait for 15 rings. The unit will answer, then hang up.
- To send the document, press **0**. The "beep" (answering carrier tone) is heard. Then start transmission.

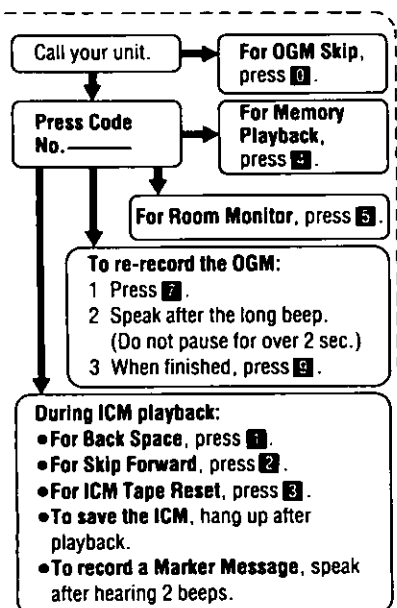

•When you press any button, press firmly.

# SERVICENTER DIRECTORY

**DIAL TOLL FREE: 1-800-CALL-FAX**

## Service in Puerto Rico

**MATSUSHITA ELECTRIC OF PUERTO RICO, INC.**

**Panasonic Sales Company/Factory Servicenter**

San Gabriel Industrial Park  
65th Infantry Avenue KM 9.5  
Carolina, Puerto Rico 00630  
(809) 750-5135

Your product is designed and manufactured to ensure a minimum of maintenance. However, should your unit ever require service, a nationwide system of **FACTORY SERVICENTERS** is maintained to support your product's warranty.

## Service in the U.S.A.... Factory Servicenters

### **MATSUSHITA SERVICES COMPANY**

Division of Matsushita Electric Corporation of America  
50 Meadowland Parkway, Secaucus, New Jersey 07094

#### **ALABAMA**

2523-5th Avenue, South  
Birmingham, AL 35233  
205-252-4195

#### **CALIFORNIA**

8550 Katella Avenue  
Cypress, CA 90630  
714-373-7426  
930 South Mt. Vernon Ave.  
Suite 200  
Colton, CA 92324  
714-825-3110  
800 Dubuque Avenue  
So. San Francisco, CA 94080  
415-871-6373  
20201 Sherman Way  
Suite 102  
Canoga Park, CA 91306  
818-709-1775  
3878 Ruffin Road  
Suite A  
San Diego, CA 92123  
619-560-9200

#### **COLORADO**

1640 South Ablene  
Suite D  
Aurora, CO 80012  
303-752-2024

#### **FLORIDA**

4115 W. Kennedy Boulevard  
Tampa, FL 33609  
813-289-9726

#### **GEORGIA**

4245 International Blvd.  
Suite C  
Norcross, GA 30093  
404-717-6880

#### **HAWAII**

99-859 Iwaiwa Street  
Aiea, HI 96701  
808-488-1996

#### **ILLINOIS**

425 E. Algonquin Road  
Arlington Heights, IL 60005  
708-981-4840

#### **MARYLAND**

Sulphur Spring Business Park,  
1638 Sulphur Spring Road,  
Baltimore, MD 21227  
301-242-2607

#### **MASSACHUSETTS**

383 University Avenue  
Westwood, MA 02090  
617-329-4280

#### **MICHIGAN**

8760 Hall Road  
Rosati Heights Plaza  
Sterling Heights, MI 48314  
313-739-1330

#### **MINNESOTA**

7850-12th Avenue, South  
Airport Business Center,  
Bloomington, MN 55425  
612-854-8624

#### **MISSOURI**

13711 Rider Trail North  
Earth City, MO 63045  
314-739-5301

#### **OHIO**

1196 W. Kemper RD  
Cincinnati, OH 45240  
513-851-4180

#### **PENNSYLVANIA**

2250 Cabot Blvd., West  
Langhorne, PA 19047  
215-741-0661  
Campbell's Run  
Business Center  
500 Business Center Drive  
Pittsburgh, PA 15205  
412-788-2174

#### **TENNESSEE**

919-8th Avenue, South  
Nashville, TN 37203  
615-244-4434

#### **TEXAS**

7420 Harwin Drive  
Houston, TX 77036  
713-781-1528  
4500 Amon Carter Blvd.  
Fort Worth, TX 76155  
817-685-1060

#### **WASHINGTON**

20425-84th Ave., South  
Kent, WA 98032  
206-872-7922

For your future reference

SERIAL NO. \_\_\_\_\_  
(found on the rear side of the unit)

DATE OF PURCHASE \_\_\_\_\_

PLACE OF PURCHASE \_\_\_\_\_

ADDRESS \_\_\_\_\_

# **QUASAR ANSWERING DEVICE WITH FACSIMILE Limited Warranty**

Quasar Company will repair this product with new or rebuilt parts, free of charge, in the U.S.A. for one (1) year from the date of original purchase in the event of a defect in materials or workmanship.

Carry-in or mail-in service in the U.S.A. can be obtained during the warranty period from a Matsushita Services Company (MSC) Factory Servicenter listed in the Servicenter Directory.

This warranty is extended only to the original purchaser. A purchase receipt or other proof of date of original purchase will be required before warranty performance is rendered.

This warranty only covers failures due to defects in materials or workmanship which occur during normal use. It does not cover damage which occurs in shipment or failures which are caused by products not supplied by Quasar Company or failures which result from accident, misuse, abuse, neglect, mishandling, misapplication, alteration, faulty installation, modification, or service by anyone other than a MSC Factory Servicenter or an authorized MSC Servicenter or damage that is attributable to acts of God, including, but not limited to, line surges.

## **LIMITS AND EXCLUSIONS**

There are no express warranties except as listed above.

QUASAR COMPANY SHALL NOT BE LIABLE FOR SPECIAL, INCIDENTAL, CONSEQUENTIAL OR PUNITIVE DAMAGES, INCLUDING, WITHOUT LIMITATION, LOSS OF GOODWILL, PROFITS OR REVENUE, LOSS OF USE OF THIS PRODUCT OR ANY ASSOCIATED EQUIPMENT, COST OF SUBSTITUTE EQUIPMENT, DOWNTIME COSTS, OR CLAIMS OF ANY PARTY DEALING WITH BUYER FOR SUCH DAMAGES, RESULTING FROM THE USE OF THIS PRODUCT OR ARISING FROM BREACH OF WARRANTY OR CONTRACT, NEGLIGENCE, OR ANY OTHER LEGAL THEORY. ALL EXPRESS AND IMPLIED WARRANTIES, INCLUDING THE WARRANTIES OF MERCHANTABILITY AND FITNESS FOR A PARTICULAR PURPOSE, ARE LIMITED TO THE APPLICABLE WARRANTY PERIOD SET FORTH ABOVE.

Some states do not allow the exclusion of limitation of consequential damages, or limitations on how long an implied warranty lasts, so the above exclusions or limitations may not apply to you.

This warranty gives you specific legal rights, and you may also have other rights which vary from state to state.

If a problem with this answering device with facsimile develops during the warranty period, you may contact your dealer or the MSC Factory Servicenter or authorized Quasar Service Dealer. If the problem is not handled to your satisfaction, write to the Quasar Company Consumer Affairs Division at the address indicated on the Servicenter Directory.

**Quasar Company**  
1325 Pratt Blvd. Elk Grove Village IL 60007  
Division of Matsushita Electric Corporation of America